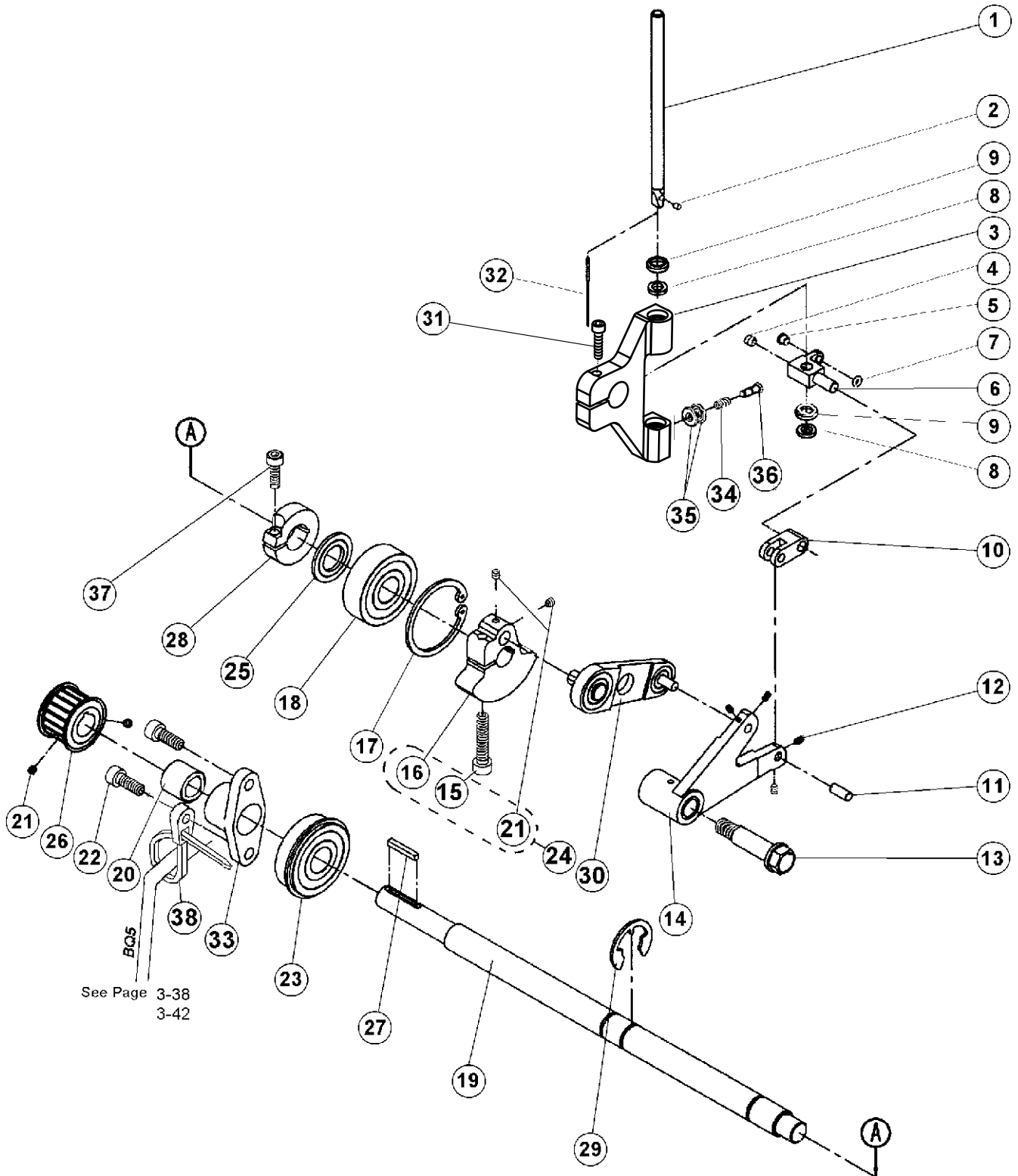

TABLE OF CONTENTS

Needle Bar.....	2
Clamping.....	4
Thread Trimmer.....	6
Shifter Mechanism.....	8
Feed Mechanism.....	10
Looper Mechanism.....	14
Base.....	16
Bite Mechanism.....	18
Knife Thread Draw-OFF Mechanism.....	20
Main Cam.....	22
Head Assembly.....	24
Bedplate.....	26
Covers.....	28
Lubrication.....	30
Table Crosswise.....	32
Table Parallel.....	34
Table Universal.....	36
Electrical — I.....	38
Electrical — II.....	42
Electrical — III.....	44
Pneumatics.....	46
Accessories — Extra Parts.....	48

NEEDLE BAR



NEEDLE BAR

DET	PART NUMBER	DESCRIPTION	QTY.
1	22.0195.0.000	Needle Bar	1
2	01.2193.0.000	4-60 Screw	1
3	24.0510.0.000	Needle Bar Holder ●	1
4	08.6400.5.005	M5 x 5 Set Screw	1
5	01.7447.1.000	Porcelain Guide ●●●	1
6	22.0520.0.000	Needle Bar Clamp	1
7	01.6551.0.000	Retaining Ring ●●●	1
8	22.0230.0.000	Cupped Washer ●●●	2
9	22.0239.0.000	Felt Washer	2
10	22.0530.0.000	Needle Bar Connecting Link	1
11	22.0542.0.000	Needle Bar Connecting Link Pin	1
12	08.6400.3.005	M3 x 5 Set Screw	4
13	22.0541.0.000	Needle Bar Shoulder Screw	1
14	22.0540.0.000	Needle Bar Connecting Link Pin ● ●●	1
15	08.6000.6.030	M6 x 30 Screw	(1)
16	22.0525.0.000	Needle Bar Crank ●	(1)
17	01.7809.0.000	Retaining Ring	1
18	01.7804.0.000	Top Shaft Bearing	1
19	24.0500.0.000	Needle Bar Drive Shaft	1
20	12.2050.0.003	Bearing	1
21	08.6400.4.004	M4 x 4 Set Screw	2 (2)
22	08.6000.6.016	M6 x 16 Screw	2
23	01.7805.0.000	Shaft Bearing	1
24	22.0525.0.050	Needle Bar Crank Asm.	1
25	22.0545.0.000	Washer	1
26	24.0048.0.000	Needle Bar Drive Pulley ●	1
27	22.0175.0.000	Drive Shaft Key	1
28	24.0002.0.000	Clamp Collar	1
29	12.1045.2.001	Retaining Ring	1
30	22.0535.0.100	Needle Bar Crank Link Asm. ●	1
31	08.6000.6.025	M6 x 25 Screw	1
32	02.0750.2.110	Needle	1
33	24.0001.0.000	Bearing Carrier Upper Shaft	1
34	22.0178.0.000	Spring	1
35	22.0177.0.000	Washer	2
36	24.0100.0.000	M3.5 x 0.35-11 Screw	1
37	08.6000.5.016	M5 x 16 Screw	1
38	12.0010.4.013	Plastic Cable Fitting	1

CLAMPING

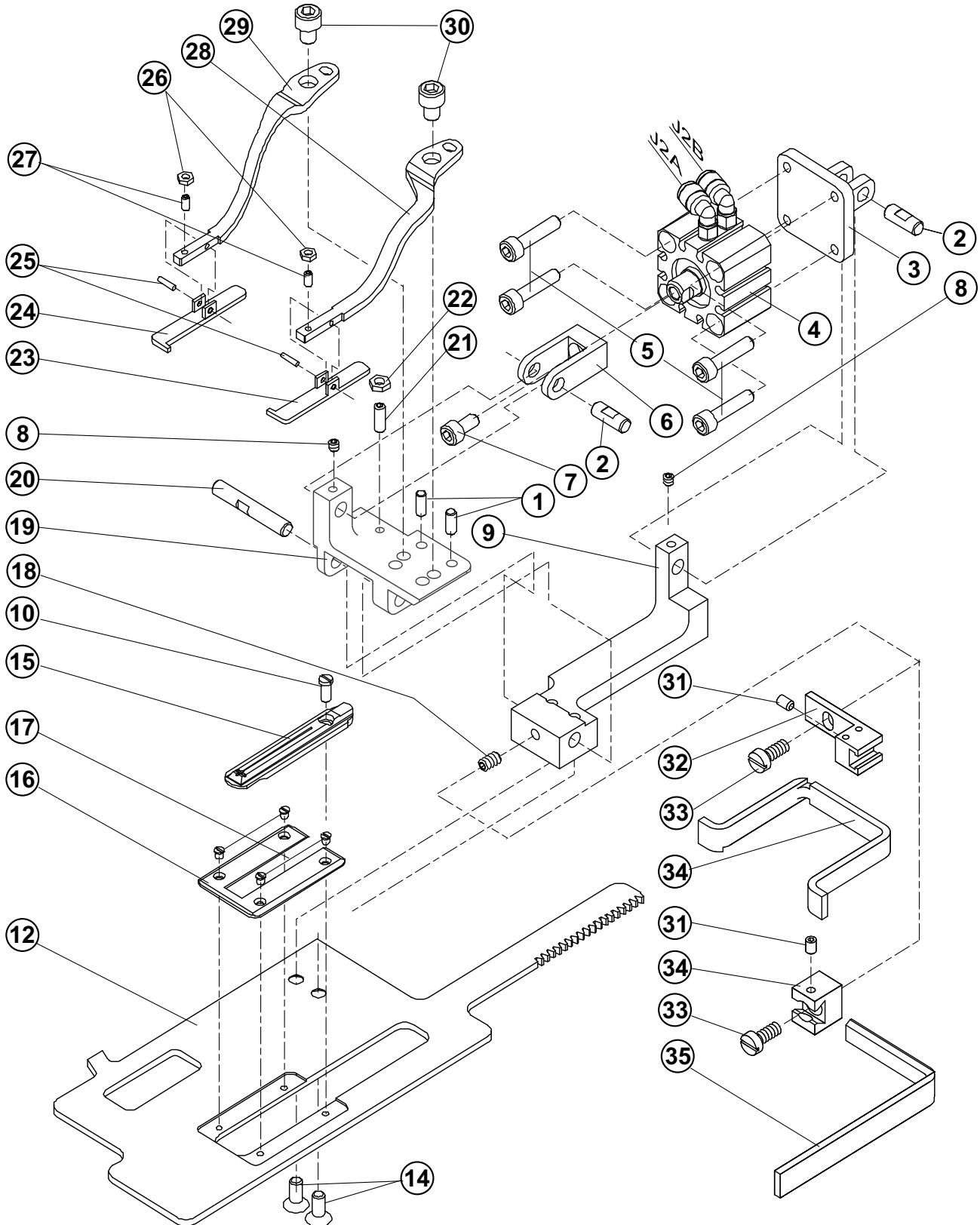

CLAMPING

DET	PART NUMBER	DESCRIPTION	QTY.
01	07.6045.0.046	Pin	2
02	22.0173.0.000	Clamp Toggle Pivot Pin	2
03	24.0036.0.000	Cylinder Mounting Bracket	1
04	See Page 3-45	Cylinder ● ● ● ●	—
05	08.6000.5.022	Screw M5 x 22	4
06	24.0035.0.000	Cylinder Clevis	1
07	08.6000.5.012	Screw M5 x 12	1
08	08.6400.4.004	Set Screw M4 x 4	2
09	24.3210.0.000	Tail Bracket Clamp	1
10	01.2084.0.000	Fill. Screw 6-52	1
12	24.0125.0.000	Clamp Plate	1
14	08.6100.5.012	Screw M5 x 12	2
15	20.0051.1.024	Throat Plate	1
16	22.0164.0.000	Clamp Mat	1
17	01.2376.0.000	Screw 4-60	4
18	08.6400.5.005	M5 x 5 Set Screw	1
19	24.3209.0.000	Tail Pivot Clamp	1
20	22.0159.0.000	Tail Pivot Clamp Pin	1
21	08.6400.4.012	Set Screw M4 x 12	1
22	08.6700.4.000	Nut M4	1
23	22.0224.0.000	R.H. Clamp Foot	1
24	22.0223.0.000	L.H. Clamp Foot	1
25	17.0031.0.460	Roll Pin	2
26	08.6710.3.000	Nut M3	2
27	08.6400.3.006	Set Screw M3 x 6	2
28	22.0227.0.000	R.H. Clamp Arm	1
29	22.0226.0.000	L.H. Clamp Arm	1
30	08.6000.6.008	Screw M6 x 8	2
31	See Page 3-49	Gauge Lock Screw M4 x 5	—
32	See Page 3-49	Crosswise Gauge Guide	—
33	See Page 3-49	Screw M5 x 8	—
34	See Page 3-49	Parallel Gauge Block	—
35	See Page 3-49	Parallel Gauge	—

THREAD TRIMMER

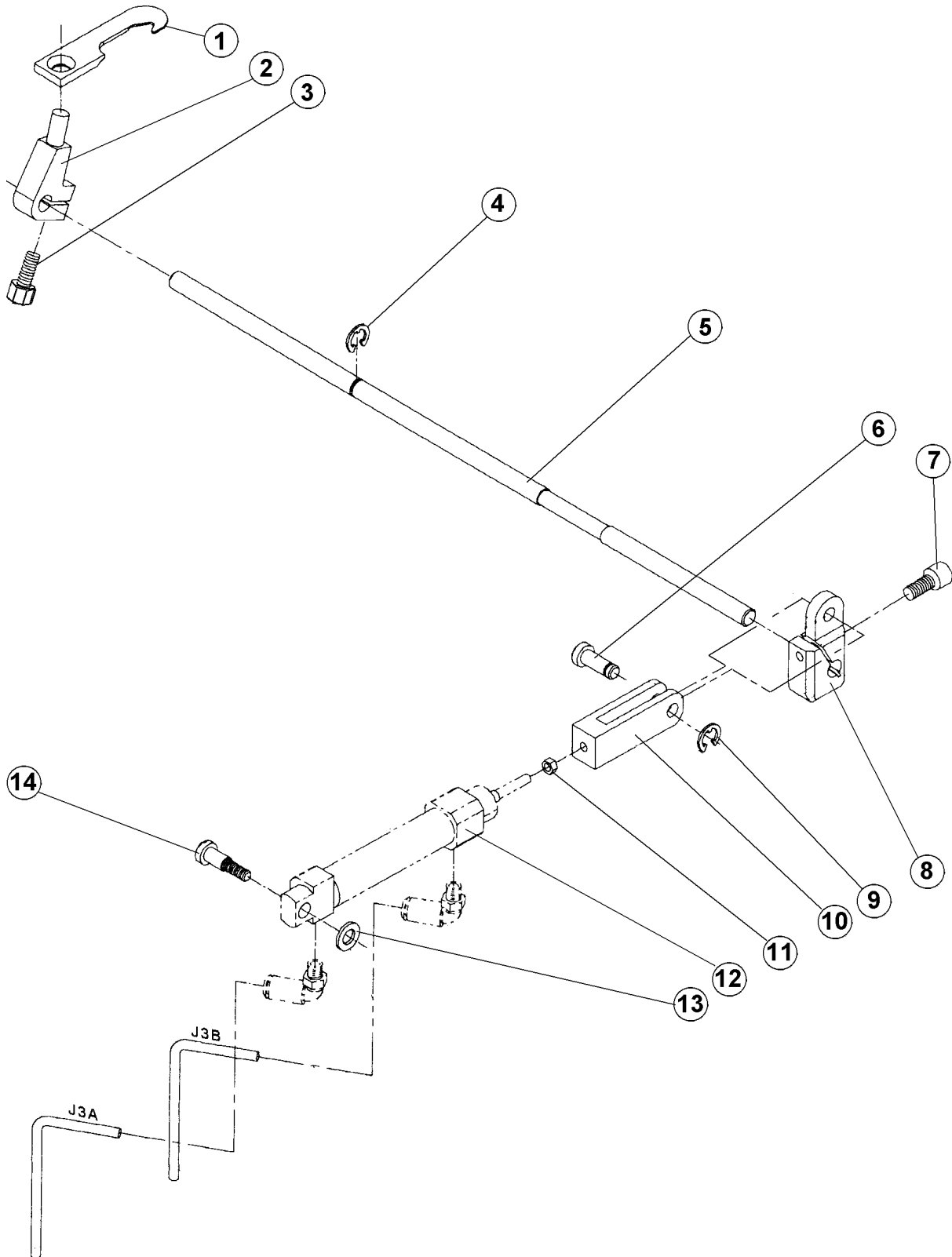

SHIFTER MECHANISM

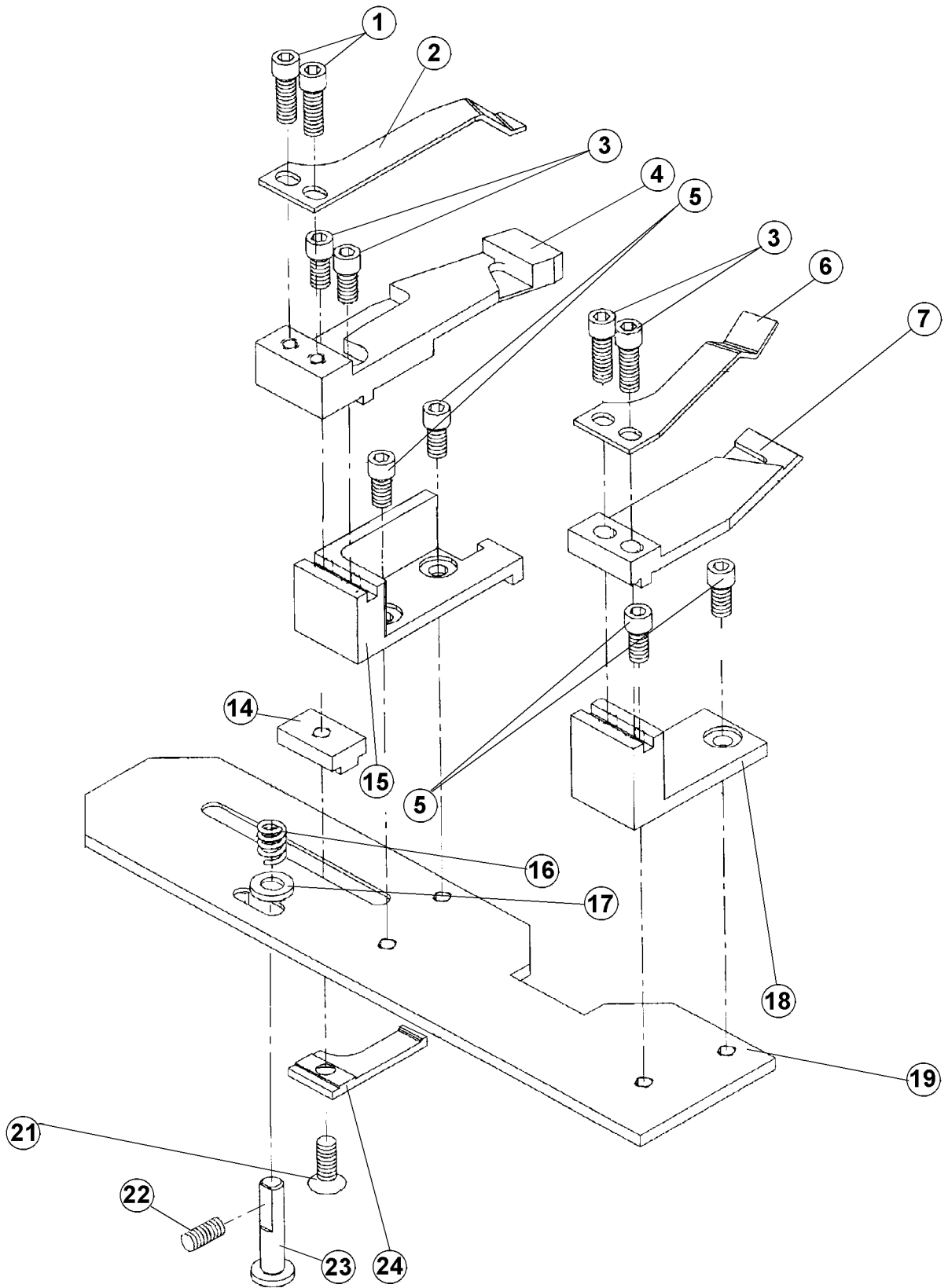

FEED MECHANISM

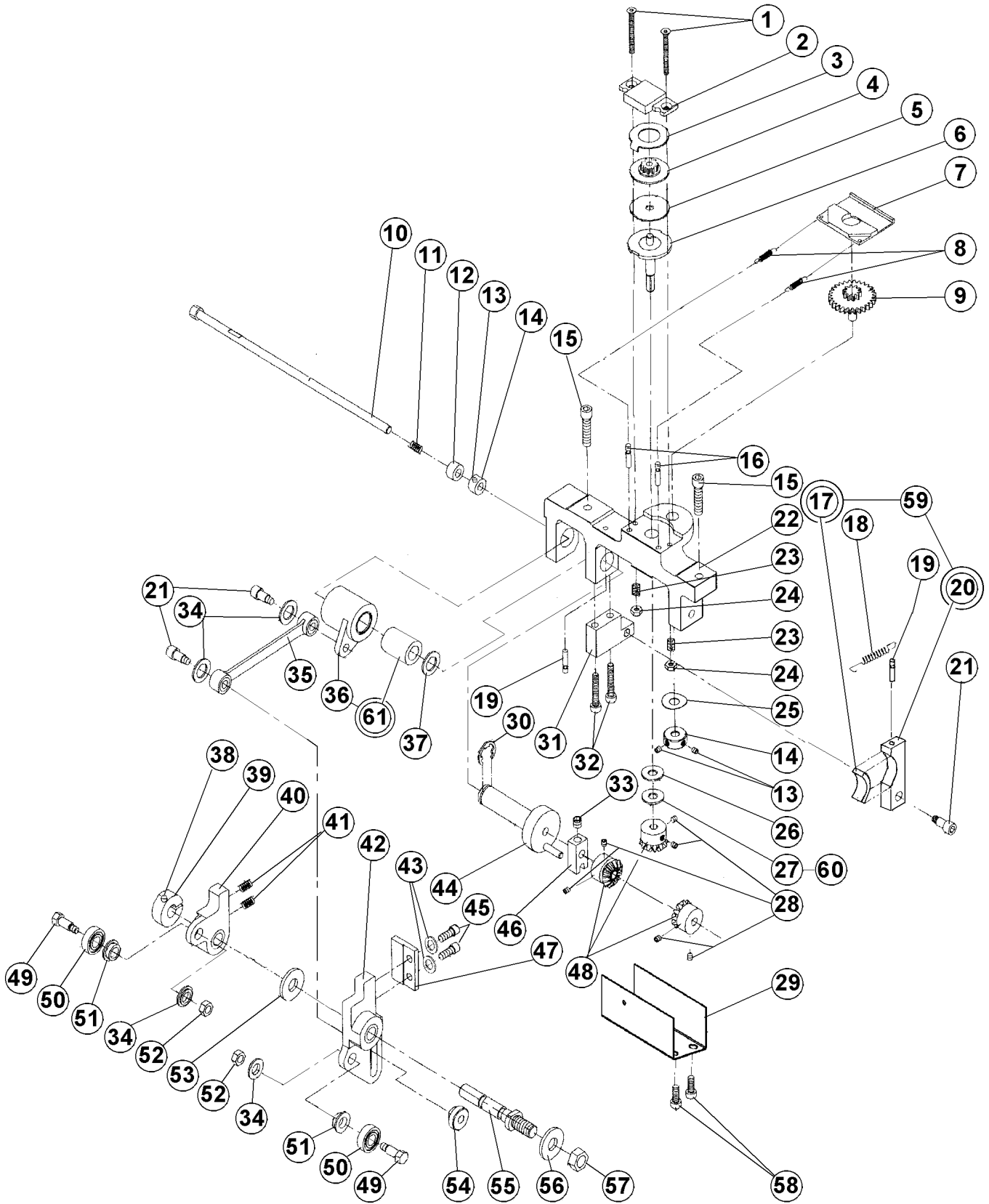

FEED MECHANISM

DET	PART NUMBER	DESCRIPTION	QTY.
01	08.6100.3.030	M3 x 30 Screw	2
02	22.0114.0.000	Feed Brake Pressure Plate	1
03	22.0121.0.000	Slip Clutch Drive Washer	1
04	22.0354.0.000	Slip Clutch Feed Gear	1
05	24.0126.0.000	Friction Washer	●●● 1
06	22.0312.0.000	Slip Clutch Feed Shaft	1
07	22.0061.0.000	Clamp Plate Gear Rack Retainer	1
08	07.6440.0.033	Spring	2
09	24.0351.0.000	Feed Gear Assembly	1
10	22.0325.0.000	Feed Reversing Shaft	1
11	07.6440.0.041	Spring	1
12	22.0228.0.000	Collar	1
13	08.6400.5.305	M5 x 0,5 - 5 Set Screw	4
14	24.0049.0.000	Set Collar	2
15	08.6000.5.020	M5 x 20 Screw	2
16	07.6045.0.037	3 x 16 Grooved Pin	2
17	22.0313.0.000	Feed Brake Pad	●●● (1)
18	07.6440.0.050	Spring	1
19	07.6045.0.009	3 x 12mm Pin	2
20	22.0309.0.000	Feed Brake	(1)
21	22.0184.0.000	M5 x 8 Screw	3
22	22.0315.0.000	Feed Shaft Bracket	●● 1
23	07.6440.0.028	Spring	2
24	08.6733.3.000	M3 Lock Nut	2
25	17.0019.2.057	Lockwasher	1
26	22.0208.0.000	Flat Washer	1
27	22.0186.0.000	Washer Dia. 5.2/17-0.2	1
28	08.6400.4.005	M4 x 5 Set Screw	6
29	24.2035.0.000	Gear Cover	1
30	07.6045.0.034	E-Ring	1
31	22.0049.0.000	Feed Brake Mounting Block	● 1
32	08.6000.4.025	M4 x 25 Screw	2
33	08.6400.5.005	M5 x 5 Set Screw	1
34	22.0100.0.000	Shoulder Washer	4
35	22.0305.0.000	Feed Connecting Link	●●● 1
36	22.0320.0.000	Feed Shaft Bearing Housing	1
37	17.0019.0.517	Washer	1
38	08.6000.3.010	M3 x 10 Screw	1
39	22.0183.0.000	Collar Dia. 8	1
40	22.0026.0.000	L.H. Feed Cam Follower	●●● 1
41	07.6440.0.018	Spring	2
42	24.0127.0.000	R.H. Feed Cam Follower	●●● 1
43	08.6800.4.000	M4 Lockwasher	2
44	22.0336.0.000	Feed Shaft	1
45	08.6000.4.014	M4 x 14 Screw	2
46	22.0370.0.000	Feed Crank	1
47	22.0021.0.000	Spring Retain Block	1
48	22.0353.0.000	Steel Bevel Gear	3
49	22.0032.0.000	Bearing Shoulder Screw	2
50	07.6321.0.025	Bearing	2

FEED MECHANISM

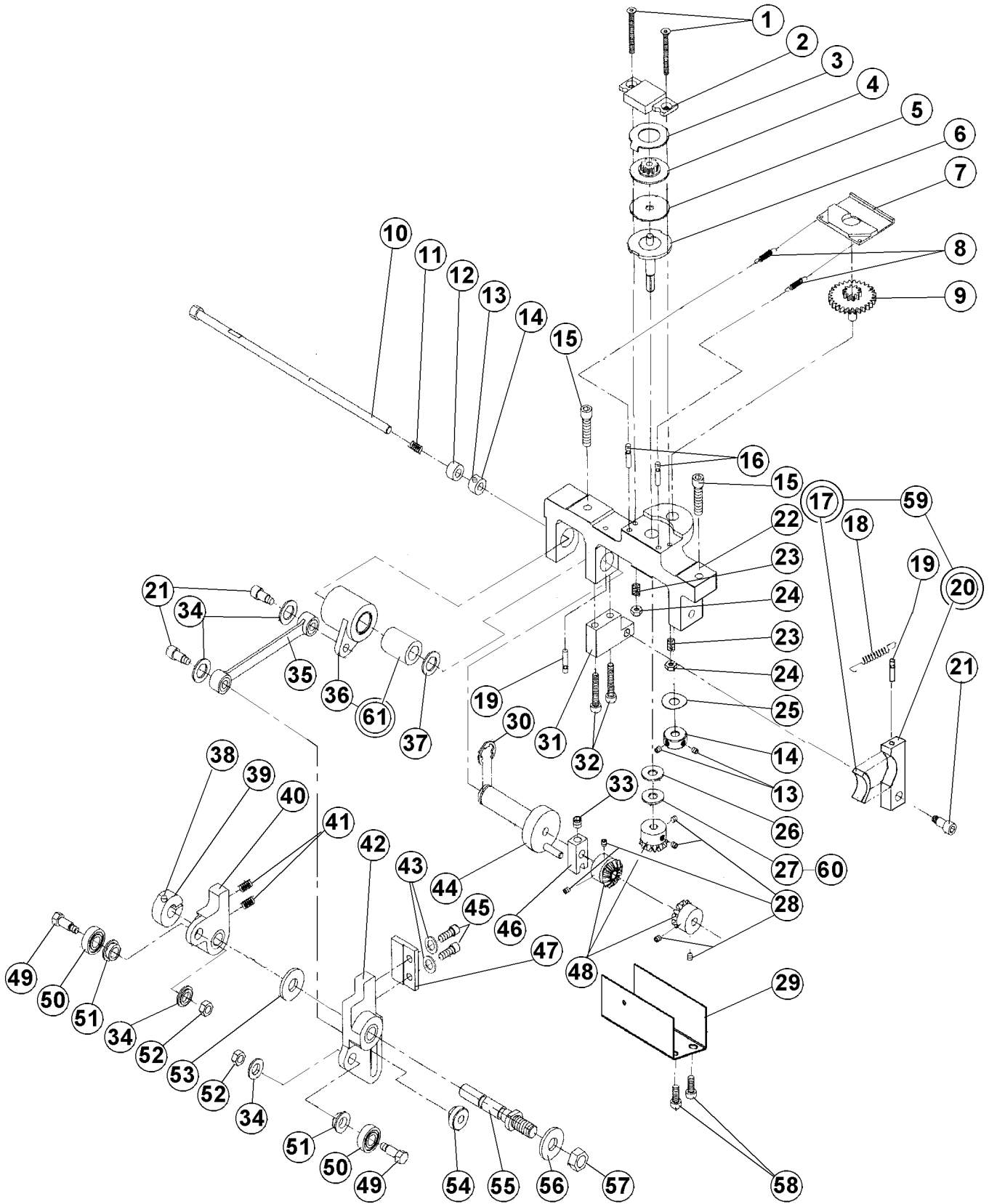

LOOPER MECHANISM

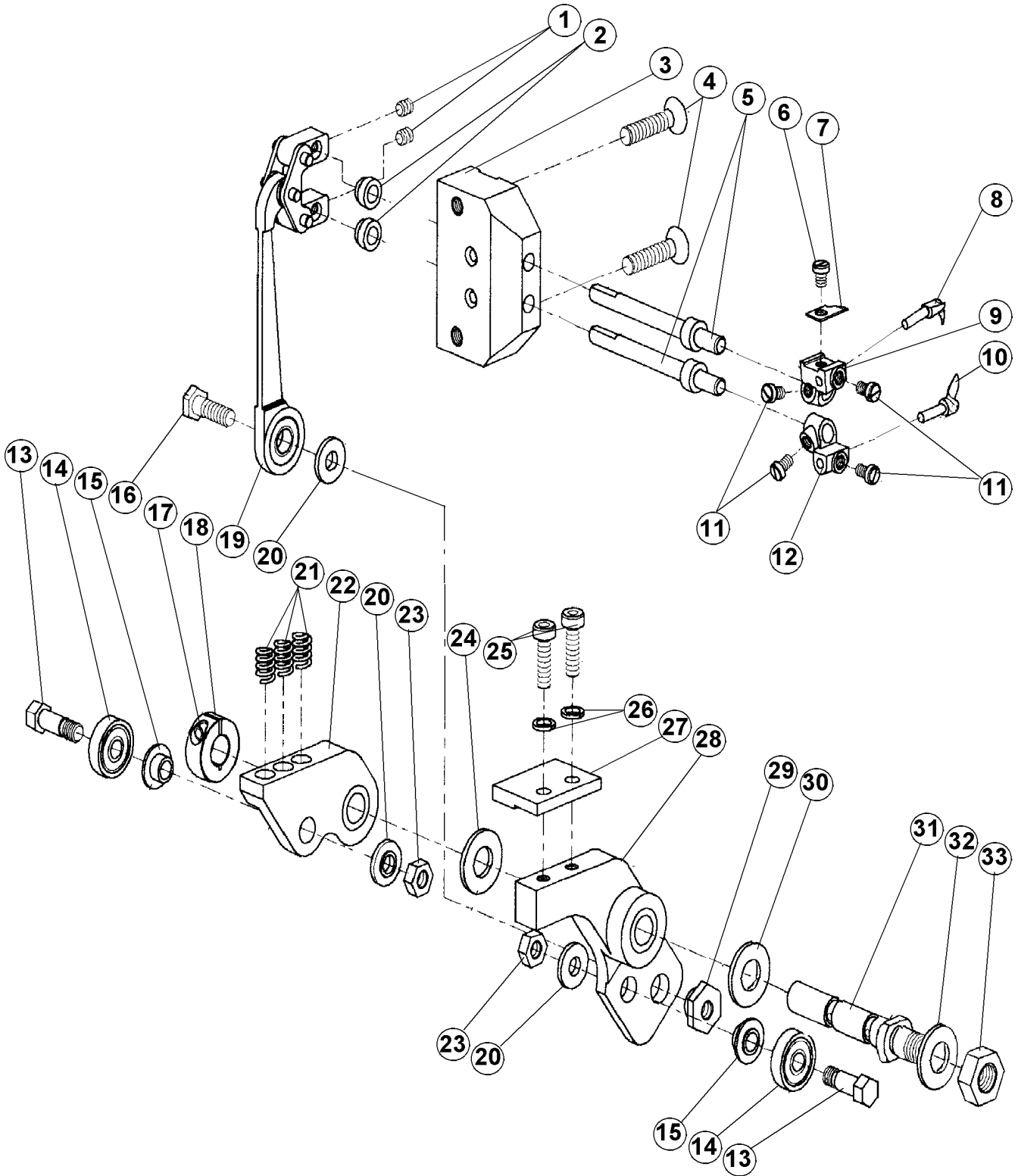

LOOPER MECHANISM

DET	PART NUMBER	DESCRIPTION	QTY.
01	08.6400.4.004	M4 x 4 Set Screw	2
02	22.2442.0.000	Looper Spacer	2
03	22.2410.0.000	Looper Shaft Block	1
04	08.6100.5.020	M5 x 20 Screw	2
05	22.2440.0.000	Looper Shaft	2
06	01.1382.0.000	Screw	1
07	20.0094.0.000	Trimmer Knife	1
08	20.0111.0.000	First Looper	1
09	23.2106.0.000	First Looper Holder	1
10	20.0112.0.000	Second Looper	1
11	01.1397.0.000	Screw	4
12	23.2107.0.000	Second Looper Holder	1
13	24.0066.0.000	Bearing Screw	2
14	12.2010.1.002	Cam Follower Bearing	2
15	22.0031.0.000	Bearing Spacer	2
16	22.0064.0.000	Bite Shoulder Screw	1
17	08.6000.3.010	M3 x 10 Screw	1
18	22.0183.0.000	Collar	1
19	22.2425.0.050	Looper Link Assembly	1
20	22.0100.0.000	Shoulder Washer	3
21	07.6440.0.036	Spring	3
22	22.0024.0.000	Looper Cam Follower Plate ● ● ●	1
23	08.6710.5.000	M5 Hex Nut	2
24	22.0232.0.000	Flat Washer	1
25	08.6000.4.014	M4 x 14 Screw	2
26	08.6800.4.000	M4 Lockwasher	2
27	22.0021.0.000	Spring Retainer Block	1
28	22.0023.0.000	R.H. Looper Cam Follower Plate ● ● ●	1
29	22.0105.0.000	Looper Eccentric Nut	1
30	22.0233.0.000	Flat Washer	1
31	22.0022.0.000	Pivot Shaft	1
32	08.6850.8.000	M8 Flat Washer	1
33	08.6700.8.000	M8 Hex Nut	1

BASE

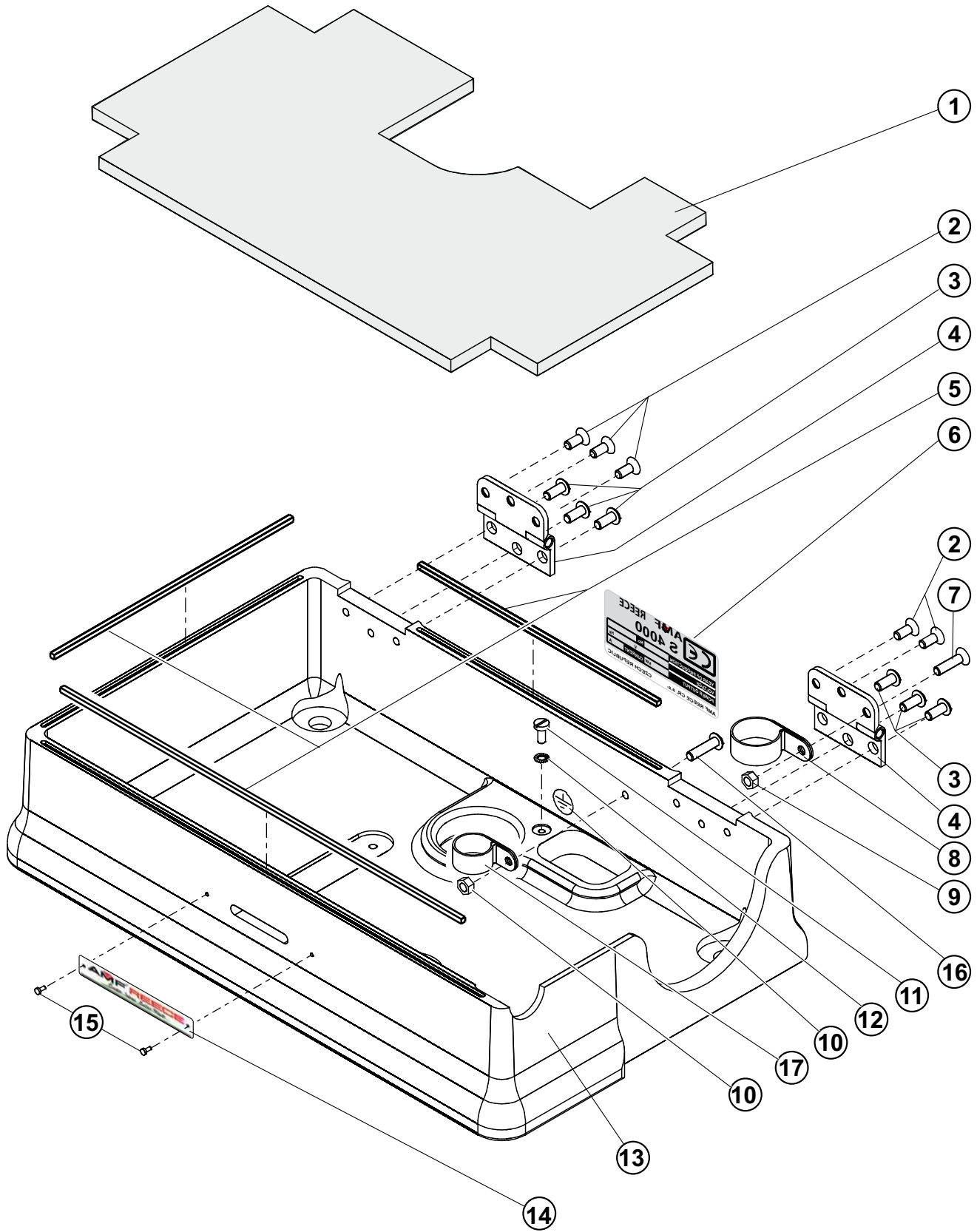

BITE MECHANISM

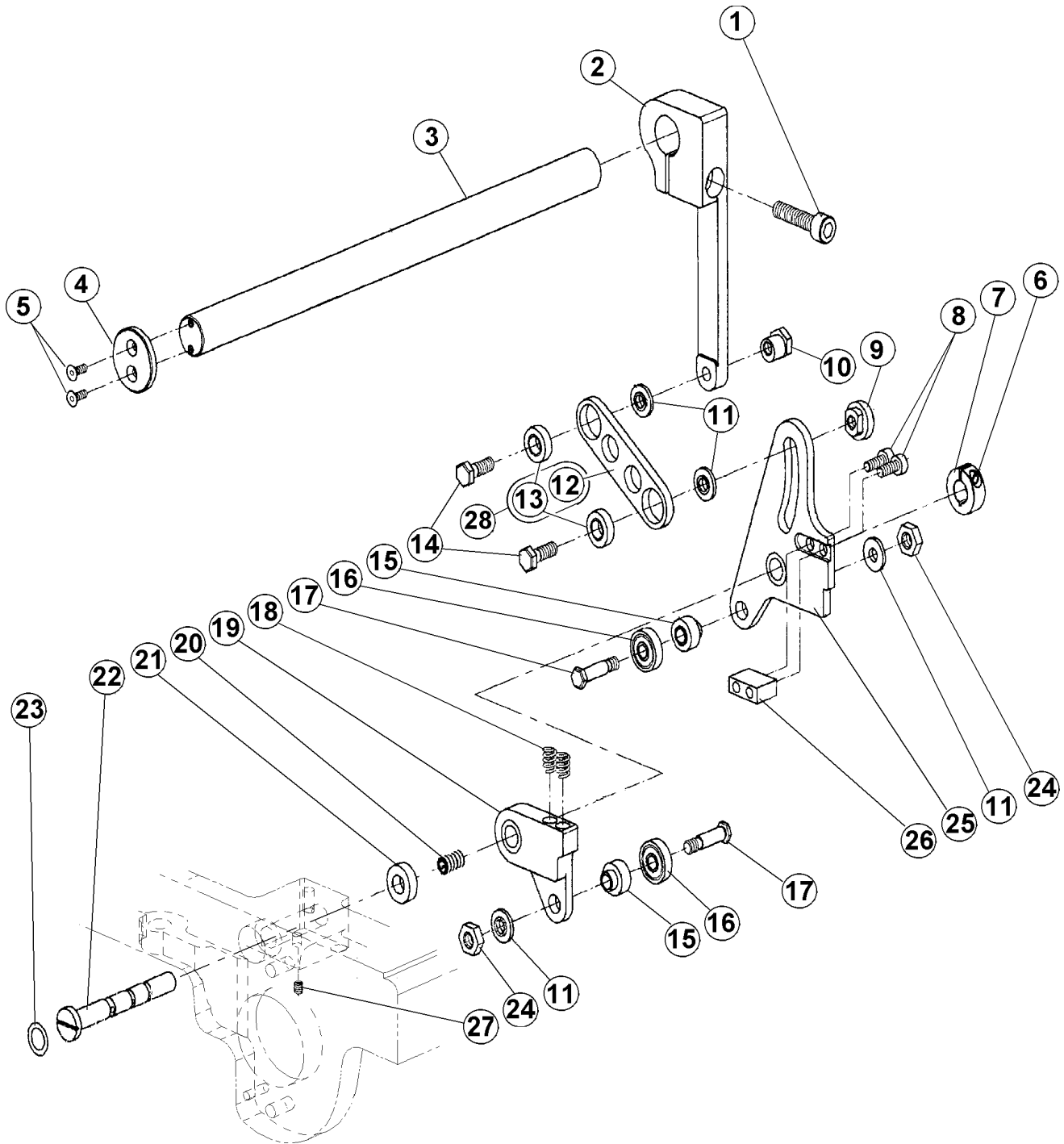

BITE MECHANISM

DET	PART NUMBER	DESCRIPTION	QTY.
01	08.6000.6.025	M6 x 25 Screw	1
02	22.0008.0.000	Bite Lever ●	1
03	24.0055.0.000	Bite Shaft	1
04	22.0063.0.000	Bite Shaft Retainer	1
05	08.6100.3.008	M3 x 8 FH Screw	2
06	08.6000.3.010	M3 x 10 Screw	1
07	22.0183.0.000	Collar*Dia. 8	1
08	08.6000.4.014	M4 x 14 Screw	2
09	22.0110.0.000	M5 Shoulder Nut	1
10	22.0214.0.000	M5 Eccentric Nut	1
11	22.0100.0.000	Shoulder Washer	4
12	22.0009.0.000	Bite Adjusting Link ●	(1)
13	07.6321.0.029	Bearing	(2)
14	22.0064.0.000	Bite Shoulder Screw	2
15	22.0029.0.000	Bite Follower Bearing Spacer	2
16	07.6321.0.025	Bearing	2
17	22.0028.0.000	Bite Follower Bearing Screw	2
18	07.6440.0.028	Spring	2
19	22.0027.0.000	Right Cam Follower ● ● ●	1
20	08.6400.4.005	M4 x 5 Set Screw	1
21	22.0069.0.000	Bite Follower Spacer	1
22	22.0020.0.000	Bite Pivot Shaft	1
23	12.0008.6.800	Rubber Ring ● ● ●	1
24	08.6700.5.000	M5 Hex Nut	2
25	22.0033.0.000	Left Cam Follower ● ● ●	1
26	22.0030.0.000	Bite Follower Spring Retainer	1
27	08.6400.4.004	M4x4 Screw	1
28	22.0009.0.050	Bite Adjusting Link Assembly	1

KNIFE THREAD DRAW-OFF MECHANISM

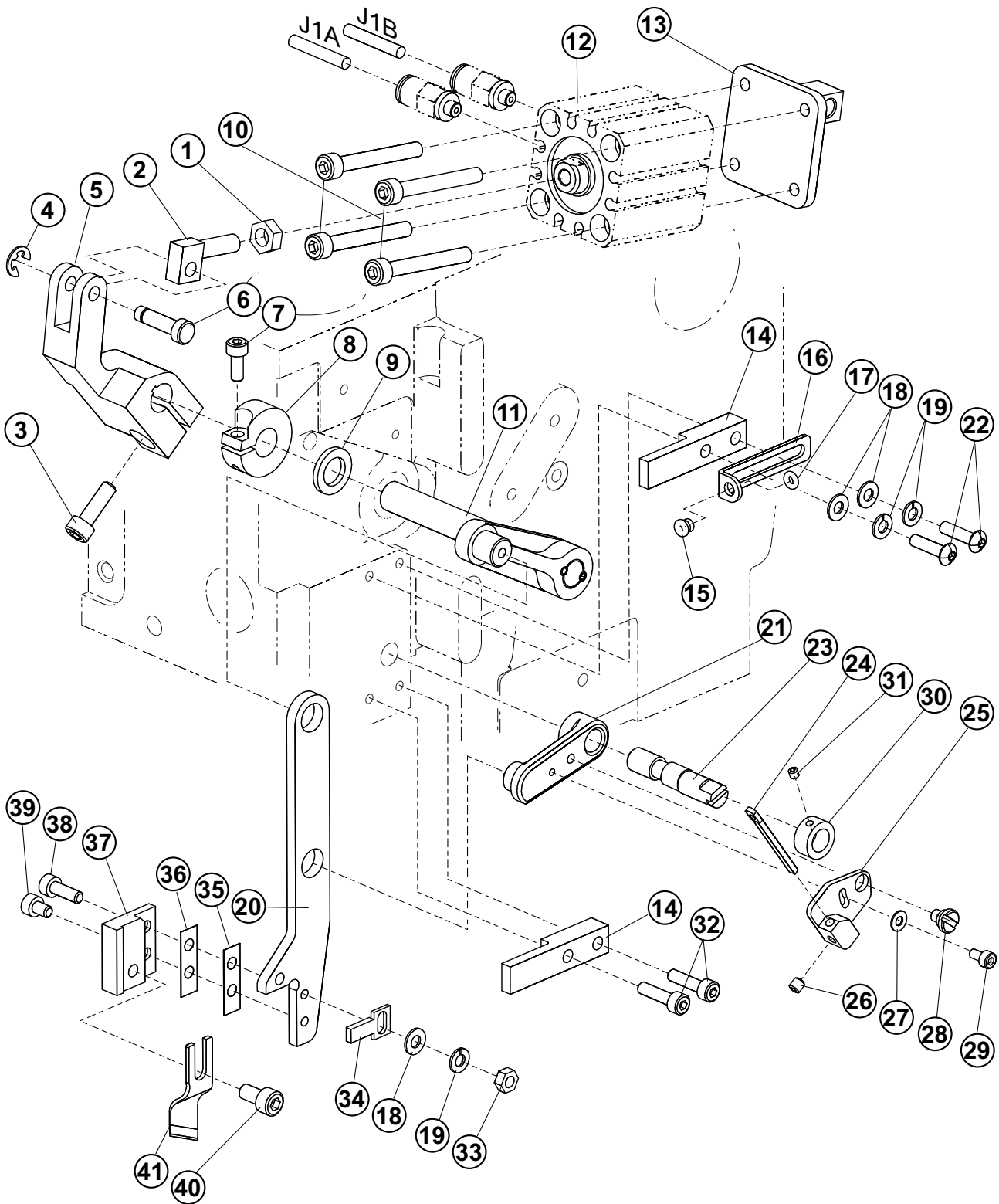

KNIFE THREAD DRAW-OFF MECHANISM

DET	PART NUMBER	DESCRIPTION	QTY.
01	08.6710.6.000	M6 Nut ●●●	1
02	24.0037.0.000	Cylinder Clevis ●●●	1
03	08.6000.5.016	M5 x 16 Screw	1
04	07.6045.0.042	E-Clip	1
05	24.0011.0.000	Knife Drive Lever	1
06	24.0014.0.000	Pivot	1
07	08.6000.4.010	M4 x 10 Screw	1
08	24.0010.0.000	Clamp Collar	1
09	24.0009.0.000	Washer	1
10	08.6000.5.040	Screw M5x40	4
11	22.1415.0.050	Knife Lever Assembly	1
12	See Page 3-47	Knife Cylinder	—
13	24.0039.0.000	Thread Draw-Off Bracket	1
14	22.1436.0.000	Drive Plate Retainer ● ●●●	2
15	01.7447.1.000	Porcelain Guide	1
16	22.0046.0.000	Thread Guide Bracket	1
17	01.6551.0.000	Retaining Ring	1
18	08.6850.4.000	M4 Flat Washer	2
19	08.6800.4.000	M4 Lockwasher	2
20	22.1430.0.901	Knife Holder	1
21	24.0062.0.000	Knife Guide Link	1
22	08.6200.4.016	M4 x 16 Screw	2
23	24.0093.0.000	Pivot Eccentric	1
24	22.0091.0.000	Thread Take-Up	1
25	24.0063.0.000	Thread Draw-Off	1
26	08.6400.4.004	M4 x 4 Set Screw	1
27	08.6850.3.000	M3 Washer	1
28	24.0061.0.000	Shoulder Screw	1
29	08.6000.3.006	M3 x 6 Screw	1
30	24.0094.0.000	Collar	1
31	08.6400.3.003	Set Screw M3x3	1
32	08.6000.4.016	Screw M4x16	2
33	08.6700.4.000	Nut M4	1
34	22.0145.0.000	Knife Stop	1
35	22.1442.0.000	Knife Shim 0,1	1
36	22.1443.0.000	Knife Shim 0,05mm	1
37	22.1426.0.000	Knife Holder Shim Block	1
38	08.6000.4.012	Screw M4x12	1
39	08.6000.4.006	Screw M4x6	1
40	08.6000.5.008	Screw M5x8	1
41	23.2356.2.052	Knife 13mm	1

MAIN CAM

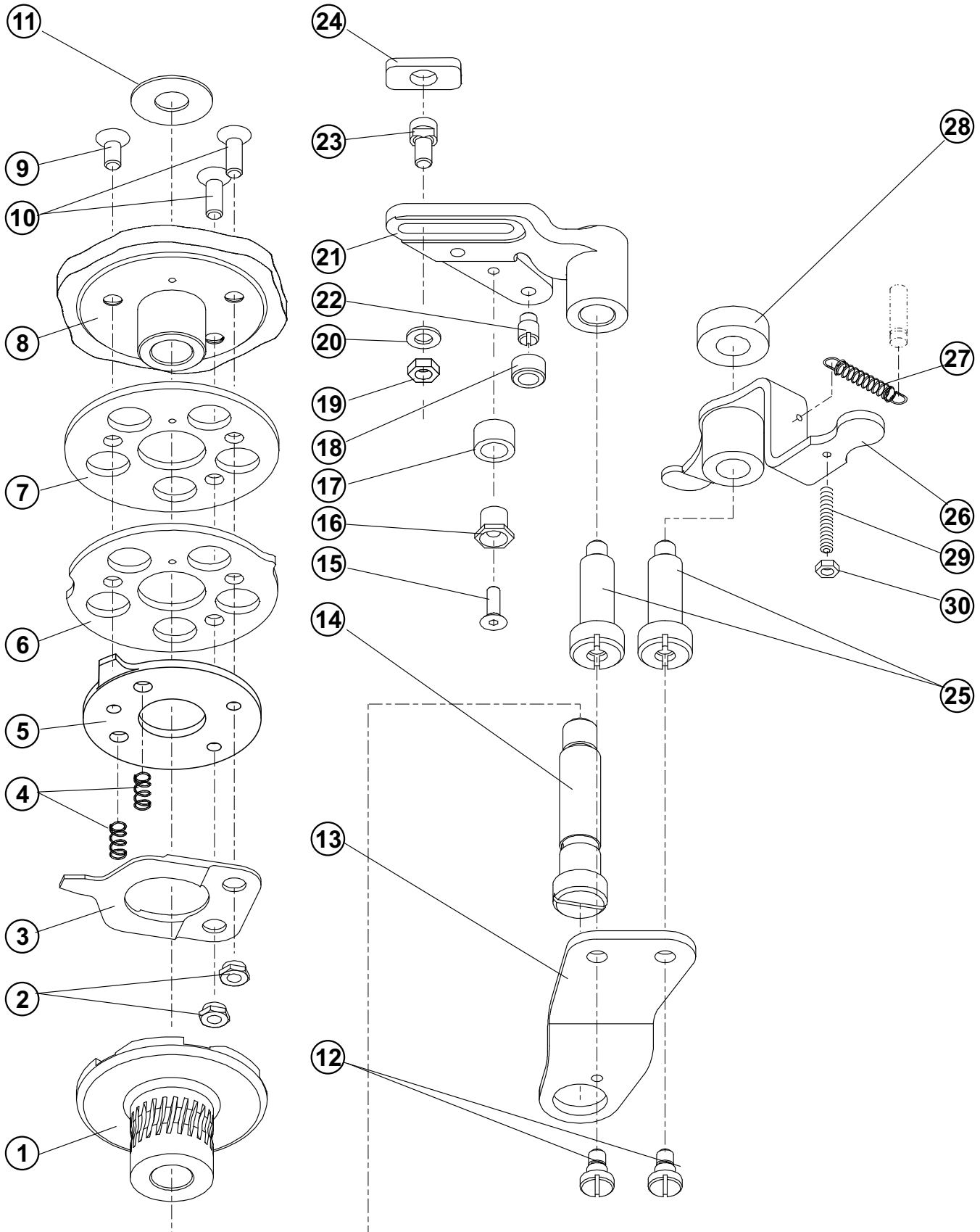

MAIN CAM

DET	PART NUMBER	DESCRIPTION	QTY.
01	22.2607.0.000	Drive Disk/Worm Gear Hub	1
02	22.2627.0.000	Shoulder Nut	2
03	22.2626.0.000	Drive Disk Switch Spring	1
04	07.6440.0.037	Spring	2
05	24.0151.0.000	Stop Disk	1
06	22.2620.0.000	Feed Reversing Cam	1
07	22.3069.0.000	Washer	1
08	22.2600.0.000	Barring Cam	1
09	08.6100.5.010	M5 x 10 Screw	1
10	22.0137.0.000	M5 x 14 Screw	2
11	07.6321.0.001	Thrust Washer	1
12	22.0182.0.000	M5 x 4 Screw	2
13	22.0097.0.000	Main Cam Brace	1
14	22.2610.0.000	Main Cam Shoulder Screw	1
15	08.6100.4.012	M4 x 12 Screw	1
16	22.2635.0.000	Barring Lever Eccentric	1
17	22.2638.0.000	Barring Lever Roller	1
18	22.2639.0.000	Barring Lever Roller	1
19	08.6700.5.000	M5 Nut	1
20	08.6850.5.000	M5 Washer	1
21	24.2630.1.000	Barring Lever	1
22	22.2637.0.000	Barring Lever Stud	1
23	22.2633.0.000	Slidestone Retaining Screw	1
24	22.2631.0.000	Clamp Plate Slidestone	1
25	22.0106.0.000	Hub Shoulder Screw	2
26	22.2640.0.050	Feed Reversing Lever	1
27	07.6440.0.045	Extension Spring	1
28	22.3003.0.000	Spacer	1
29	08.6400.3.020	Screw M3x20	1
30	08.6700.3.000	Nut M3	1

HEAD ASSEMBLY

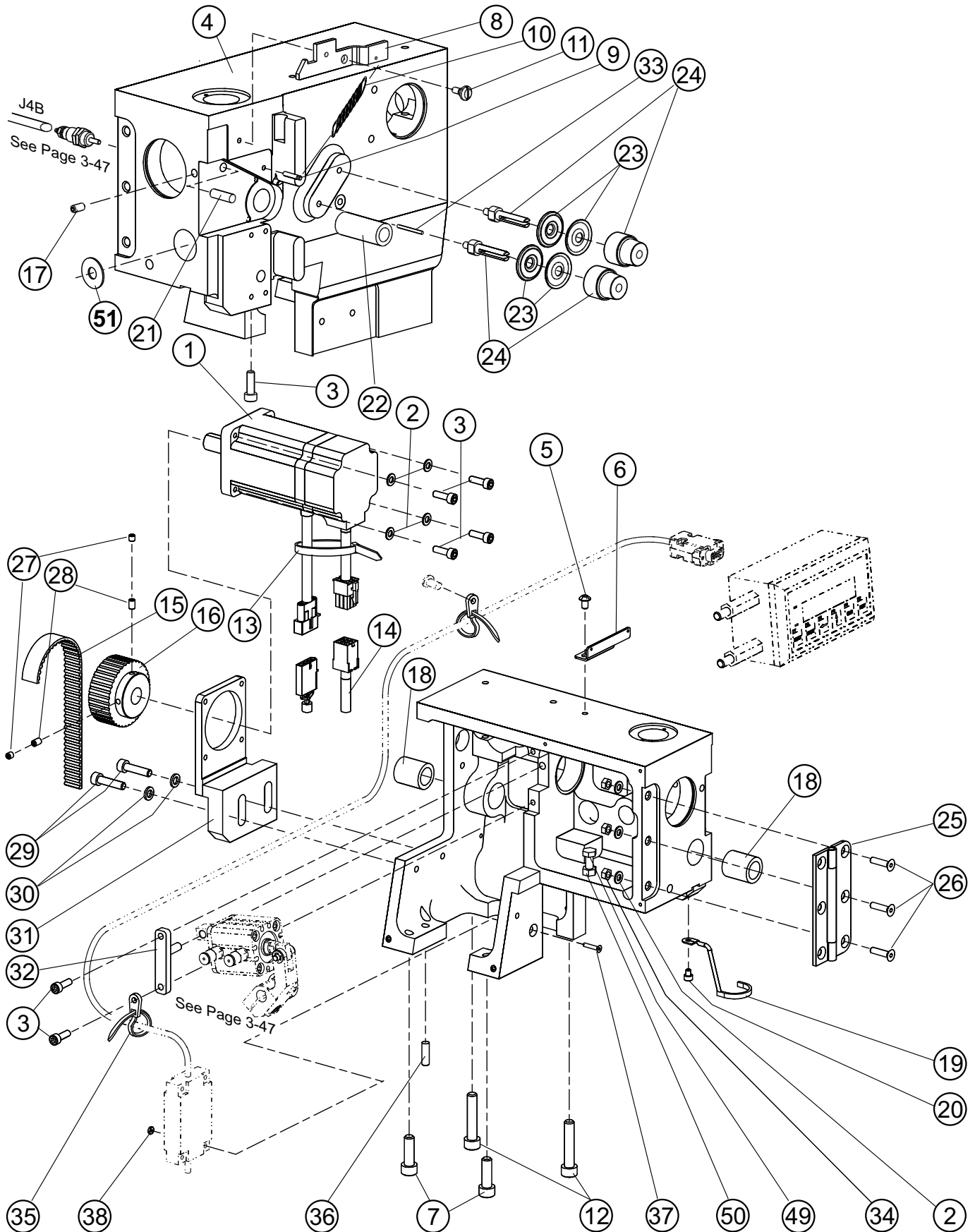

HEAD ASSEMBLY

DET	PART NUMBER	DESCRIPTION	QTY.
01	See Page 3-39	Servomotor ● ● ● ● ●	1
02	08.6850.5.000	M5 Washer	7
03	08.6000.5.016	M5 x 16 Screw	8
04	24.6000.5.000	Head	1
05	08.6200.5.008	M5 x 8 Screw	1
06	22.0054.0.000	Upper Thread Guide	1
07	08.6000.8.025	M8 x 25 Screw	2
08	22.0058.0.000	Sewing Head Latch	1
09	07.6045.0.037	3 x 16 Grooved Pin	1
10	07.6440.0.051	Latch Tension Spring	1
11	22.0062.0.000	M4 x 3 Screw	1
12	08.6000.8.040	M8x40 Screw	2
13	12.0008.3.023	Ty-wrap ●	1
14	See Page 3-39	Encoder Cable ● ● ● ● ●	1
15	12.5050.2.009	Belt ● ● ● ●	1
16	24.0108.0.000	Motor Pulley ●	1
17	08.6400.5.010	M5 x 10 Screw	1
18	01.7806.0.000	Oilite Bushing ● ●	2
19	24.0044.0.000	Needle Guard	1
20	08.6000.4.005	M4 x 5 Screw	1
21	07.6045.0.053	6 x 20 Pin	1
22	22.1422.0.000	Knife Shaft Bushing	1
23	17.0082.8.082	Release Washer	2
24	23.2044.0.050	Large Tension Assembly ● ● ●	2
25	22.6002.0.000	Head Hinge Assembly	1
26	08.6100.5.020	M5 x 20 Screw	3
27	08.6400.5.005	M5 x 5 Set Screw	2
28	08.6400.5.008	M5x8 Set Screw	2
29	08.6000.6.025	M6 x 25 Screw	2
30	08.6850.6.000	M6 Washer	2
31	24.0106.0.000	Motor Bracket	1
32	24.0016.0.000	Cylinder Pivot Stud Assembly	1
33	12.1010.2.003	2 x 24 Pin	1
34	08.6700.5.000	M5 Nut	3
35	12.0008.4.598	Plastic Cable Fitting ● ● ●	1
36	12.1011.0.001	6 x 20 Pin	1
37	08.6100.3.016	M3 x 16 Screw	1
38	08.6700.3.000	M3 Nut	1
49	08.6310.6.035	Screw M6x35	1
50	08.6700.6.000	Nut M6	1
51	24.0546.0.000	Washer	1

BEDPLATE

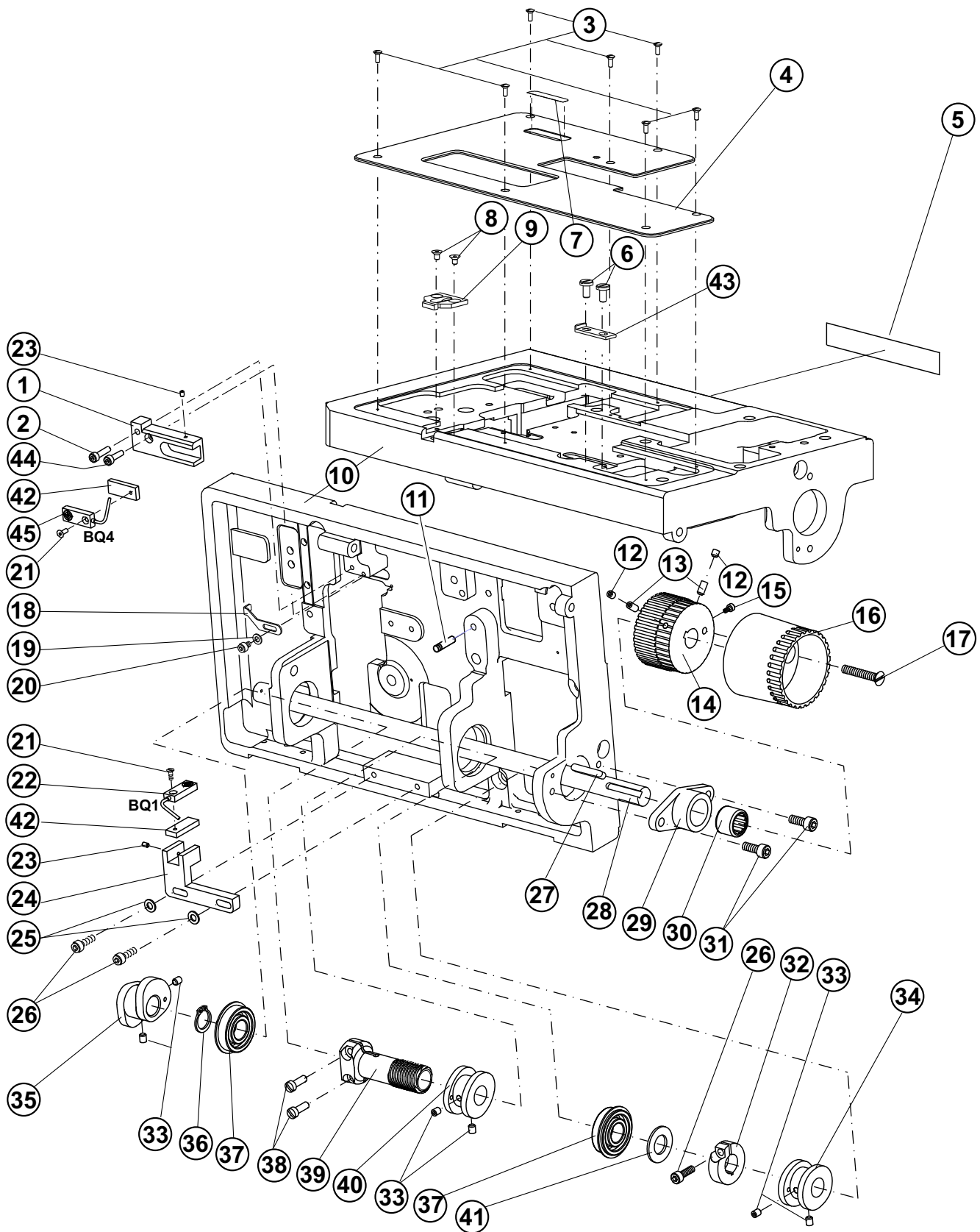

BEDPLATE

DET	PART NUMBER	DESCRIPTION	QTY.
1	24.0021.0.000	Tension Release Sensor Bracket	1
2	08.6000.4.014	M4x14 Screw	1
3	08.6120.3.008	M3x8 Screw	7
4	22.6101.0.000	Cover Plate	1
5	—	AMF Reece Label - small	1
6	22.0143.0.000	Screw	2
7	22.0096.0.000	Buttonhole Size Sticker	1
8	08.6100.4.006	M4x6 Screw	2
9	22.0408.1.000	Trimmer Cover Plate	1
10	24.6100.0.000	Bedplate	1
11	07.6045.0.054	5 x 20 mm Pin	1
12	08.6400.5.005	M5 x 5 Set Screw	2
13	08.6400.5.010	M5 x 10 Set Screw	2
14	24.0018.0.000	Main Shaft Drive Pulley ●	1
15	08.6000.3.006	M3 x 6 Screw	1
16	24.0051.0.066	Hand Wheel ●	1
17	08.6100.6.035	M6 x 35 Screw	1
18	22.3219.0.000	Needle Guard	1
19	08.6850.4.000	M4 Washer	1
20	08.6000.4.006	M4 x 6 Screw	1
21	08.6100.3.008	M3 x 8 Screw	2
22	See Page 3-39	End of Cycle Sensor with Cable (BQ1) ●●●	—
23	08.6400.3.004	M3 x 4 Set Screw	2
24	24.0020.0.000	End of Cycle Sensor Bracket	1
25	08.6850.5.000	M5 Washer	2
26	08.6000.5.016	M5 x 16 Screw	3
27	12.4030.0.002	Key 5x5x30	1
28	24.1000.0.000	Main Shaft	1
29	24.0019.0.000	Bearing Carrier Lower Shaft	1
30	12.2050.0.005	Bearing	1
31	08.6000.6.016	M6 x 16 Screw	2
32	24.0002.0.000	Clamp Collar	1
33	08.6400.5.305	M5 x 0.5-5 Set Screw	6
34	22.0006.0.000	Bite Cam	1
35	24.2400.0.000	Looper Cam	1
36	12.1045.2.001	Retaining Ring	1
37	01.7805.0.000	Shaft Bearing	2
38	22.0153.0.000	Screw	2
39	22.8400.0.000	Shaft Worm Gear	1
40	22.0300.0.000	Feed Cam	1
41	22.0545.0.000	Washer	1
42	24.0027.0.000	Sensor Mounting Plate	2
43	22.0115.0.000	Stop	1
44	08.6000.4.016	M4x16 Screw	1
45	See Page 3-39	Tension Release Sensor with Cable (BQ4)	1

COVERS

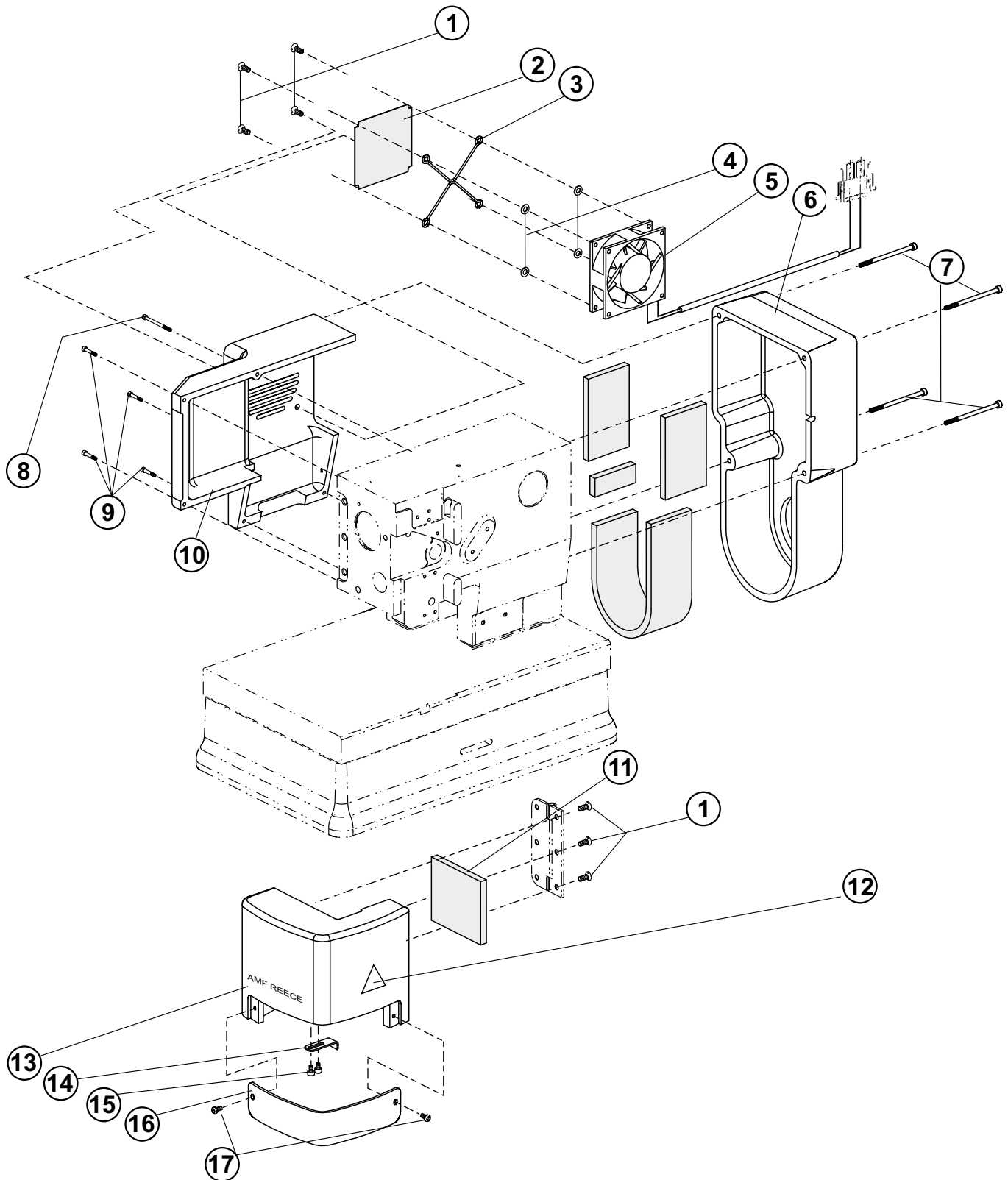

COVERS

DET	PART NUMBER	DESCRIPTION	QTY.
01	08.6100.5.016	Screw M5 x 16	7
02	24.0068.0.000	Net ●●●	1
03	24.0067.0.000	Fan Rack	1
04	08.6850.5.000	Washer M5	4
05	See Page 3-35	Fan Assembly ●●●●	—
06	24.6004.1.001	Pulley Cover ●	1
07	08.6000.4.070	Screw M4 x 70	4
08	08.6000.3.040	Screw M3 x 40	1
09	08.6000.3.016	Screw M3 x 16	4
10	24.6001.2.000	Head Rear Cover ●	1
11	24.0112.0.000	Cover Sound Deadener ●●●	1
12	—	Label	1
13	24.6003.0.000	Needle Bar Cover ●	1
14	22.0057.0.000	Cover Latch	1
15	08.6000.4.006	Screw M4 x 6	2
16	24.0154.0.000	Eye Shield ●●●	1
17	08.6200.4.008	Screw M4 x 8	2

LUBRICATION

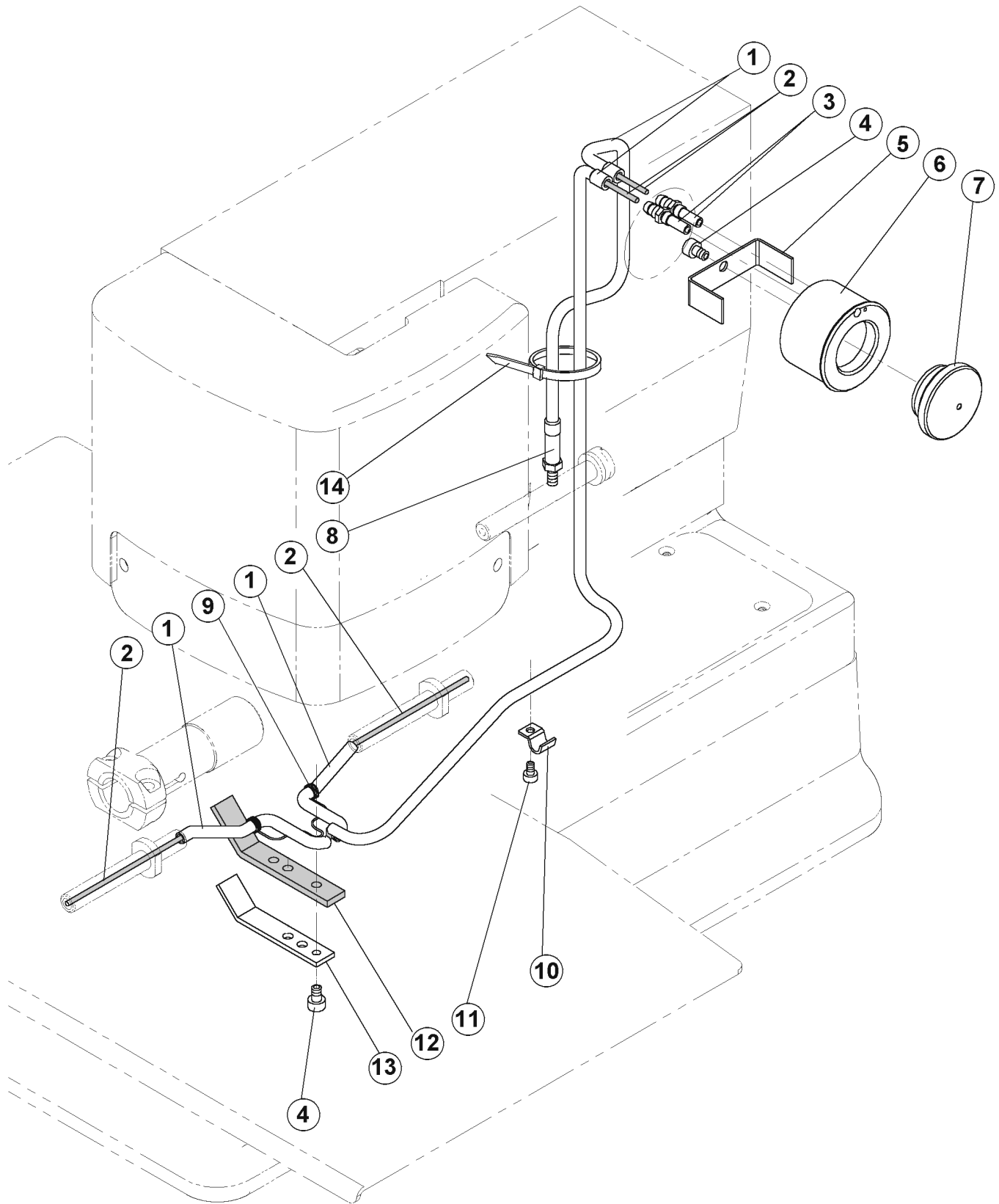

LUBRICATION

DET	PART NUMBER	DESCRIPTION	QTY.
01	24.0141.0.000	Tubing ●●●	1
02	24.0139.0.000	Lubricating Wick ●●●	1
03	22.0229.0.000	Straight Fitting	2
04	08.6000.4.006	M4 x 6 Screw	2
05	22.0120.0.000	Holder	1
06	22.0104.0.000	Oil Gauge Reservoir	1
07	17.0095.1.329	Wheel ●●●	1
08	22.0108.0.000	Wick Holder	1
09	17.0027.1.799	Spring	1
10	17.0082.6.000	Clamp	1
11	08.6000.3.006	M3 x 6 Screw	1
12	17.0094.5.310	Felt ●●●	1
13	22.0107.0.000	Worm Gear Felt Retainer	1
14	12.0008.3.023	Ty-wrap ●●●	1

TABLE CROSSWISE

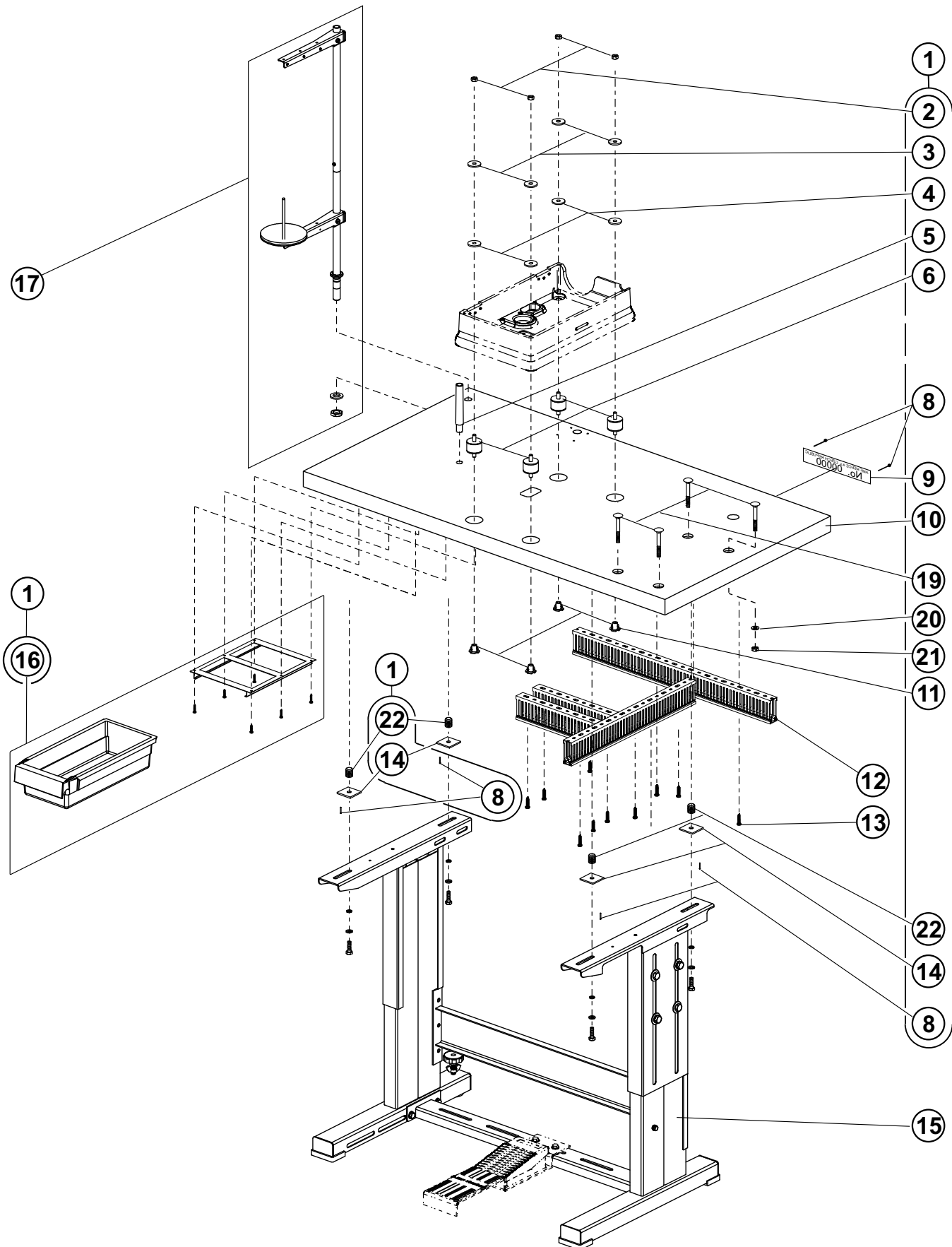

TABLE PARALLEL

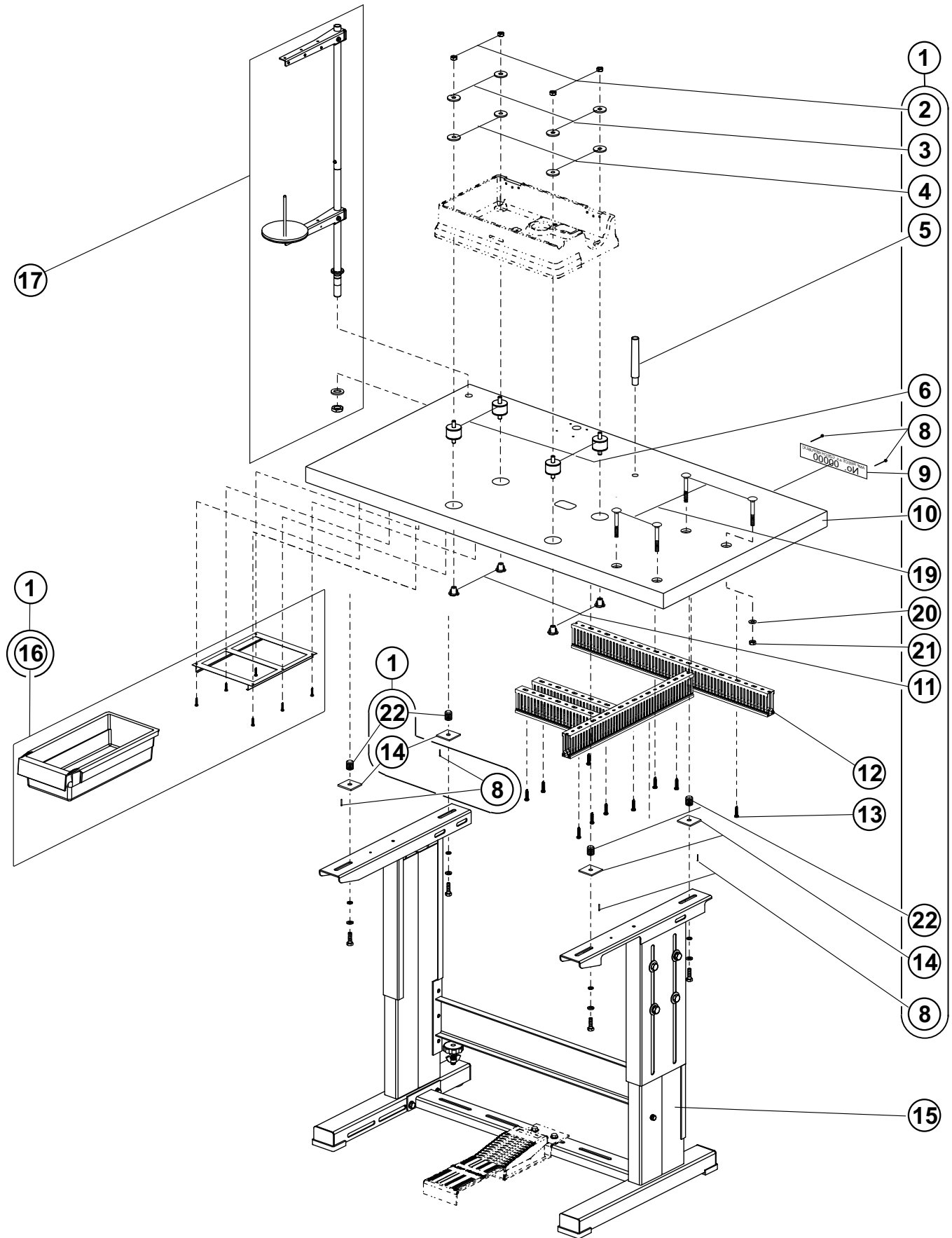

TABLE PARALLEL

DET	PART NUMBER	DESCRIPTION	QTY.
01	24.0149.0.050	Table Crosswise Assembly	1
02	08.6700.8.000	M8 Nut	(4)
03	17.0019.0.441	Washer	(4)
04	17.0095.1.272	Washer	●●● (4)
05	12.0008.6.900	Machine Rest Table Pin	(1)
06	12.0008.6.801	Rubber Spring	●●● (4)
08	12.1016.1.000	Nail	●●● (6)
09	04.1416.0.003	Label "No. xxxx"	(1)
10	24.0149.0.000	Table Crosswise	●●● (1)
11	08.6742.8.000	M8 Nut	(4)
12	24.0059.9.065	Wire Raceway Kit	●●● 1
13	08.6663.5.025	Screw 4,8 - 25	10
14	17.0094.0.200	Washer	●●● (4)
15	04.9000.2.123	Frame Kit	1
16	12.0008.6.901	Drawer Kit	●●● (1)
17	22.0219.0.000	Thread Stand	1
19	08.6532.8.055	Screw M8x55	(4)
20	08.6852.8.000	Washer	(4)
21	08.6702.8.000	Nut	(4)
22	08.6752.8.000	Nut	(4)

TABLE UNIVERSAL

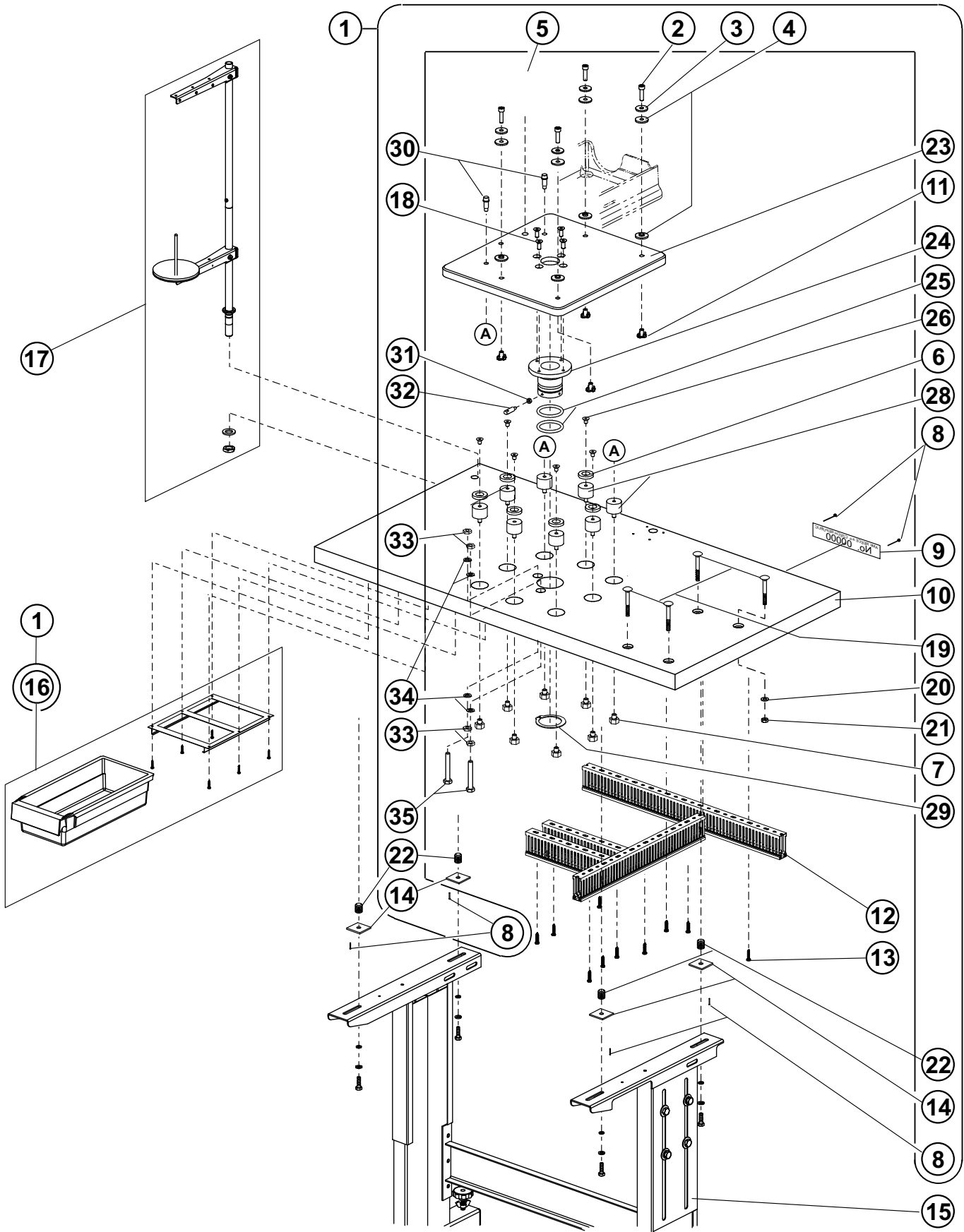
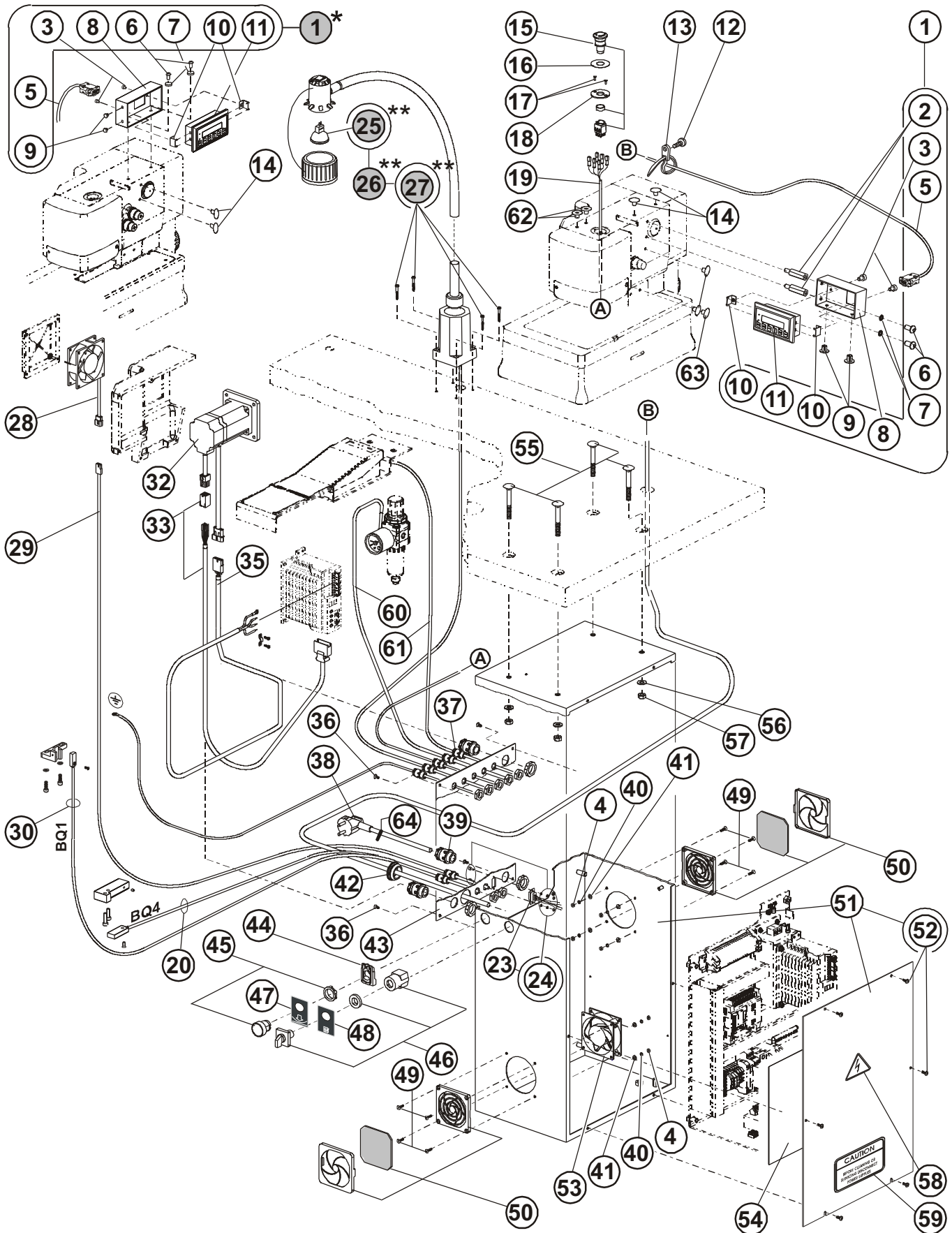

TABLE UNIVERSAL

DET	PART NUMBER	DESCRIPTION	QTY.
01	24.0150.0.050	Table Assembly	1
02	08.6000.8.030	Screw M8x30	(4)
03	17.0019.0.441	Washer	(4)
04	17.0095.1.272	Washer	●●● (8)
05	12.0008.6.900	Machine Rest Table Pin	(1)
06	24.0081.0.000	Bearing Disk	●●● (6)
07	24.0082.0.000	Retaining Nut	0
08	12.1016.1.000	Nail	●●● (6)
09	04.1416.0.003	Label "No. xxxx"	(1)
10	24.0150.0.000	Table	●●● (1)
11	08.6742.8.000	M8 Nut	(4)
12	24.0059.9.065	Wire Raceway Kit	●●● 1
13	08.6663.5.025	Screw 4,8 - 25	10
14	17.0094.0.200	Washer	●●● (4)
15	04.9000.2.123	Frame Kit	1
16	12.0008.6.901	Drawer Kit	●●● (1)
17	22.0219.0.000	Thread Stand	1
18	08.6100.8.020	Screw M8x20	(4)
19	08.6532.8.055	Screw M8x55	(4)
20	08.6852.8.000	Washer	(4)
21	08.6702.8.000	Nut	(4)
22	08.6752.8.000	Nut	(4)
23	24.0079.0.000	Base Plate	(1)
24	24.0086.0.000	Pivot, Base Subplate	(1)
25	12.0008.6.807	O Ring 50x6	(2)
26	08.6100.8.012	Screw M8x12	(6)
28	24.0084.0.000	Cylindrical Vibrator Isolator	(8)
29	12.1040.1.009	Ring 58	(1)
30	24.0087.0.000	Shoulder Screw	(2)
31	08.6700.6.000	Nut M6	(1)
32	24.0089.0.000	Stop Pin	(1)
33	08.6710.0.300	Nut M10	(4)
34	08.6850.0.000	Washer M10	(4)
35	08.6300.0.070	Screw M10x70	(2)

ELECTRICAL — I



ELECTRICAL — I

DET	PART NUMBER	DESCRIPTION	QTY.
01	03.5524.0.009	Panel Kit for Table Parallel	1
01*	03.5524.0.009	Panel Kit for Table Crosswise	1
02	12.0008.4.565	Screw	(2)
03	08.6000.4.006	Screw	(2)
04	08.6702.4.000	Nut M4	8
05	12.0008.4.574	Cable	(1)
06	08.6200.6.012	Screw	(2)
07	08.6832.6.000	Serrated Washer	(2)
08	24.0146.0.000	Display Box	(1)
09	12.0008.4.571	Plug	(2)
10	24.0147.0.000	Panel Holder	(2)
11	24.8001.0.005	Display	(1)
12	08.6200.6.016	Screw M6x16	1
13	12.0010.4.013	Plastic Cable Fitting	1
14	12.0008.4.570	Plug	2
15	12.0008.4.563	Emergency Stop Button	1
16	12.8000.0.047	Label	1
17	08.6102.3.008	Screw	2
18	24.0148.0.000	Emergency Stop Cover	1
19	24.0069.9.023	Emergency Stop Cable	1
20	24.0069.9.022	Tension Release Sensor Witch Cable (BQ4)	1
23	24.0069.9.024	Cable	1
24	12.0008.4.710	Screw Kit	1
25**	12.0008.4.679	Bulb 12V/12W	(1)
26**	12.0008.4.403	Halogen Lamp Kit 12 V Assembly	1
27**	—	Screw	(4)
28	24.0059.9.069	Fan	1
29	24.0069.9.027	Fan Cable	1
30	24.0069.9.006	End of Cycle Sensor with Cable (BQ1)	1
32	24.0059.9.064	Servomotor Assembly	1
33	24.0069.9.008	Encoder Cable	1
35	24.0069.9.002	Motor Power Cable	1
36	08.6100.4.010	Screw	4
37	12.0008.4.207	Bushing	●●● 7
38	12.0008.4.713	Cable	1
39	12.0008.4.231	Bushing	3
40	08.6802.4.000	Washer	4
41	08.6852.4.000	Washer	4
42	12.0008.4.366	Plug PG 29	1
43	24.0138.0.000	Connectors Plate ISBH	1
44	12.0008.4.863	Block	1
45	12.0008.4.861	Switch (Black)	1
46	12.0008.4.835	Switch ON — OFF	1
47	12.8000.0.041	Label (Clamp Up/Down)	1
48	12.8000.0.040	Label	1
49	08.6100.4.014	Screw	1
50	12.0008.4.762	Fan Cover With Filter	●●● 2
*	For Table Parallel		
**	Extra Parts		

ELECTRICAL — I

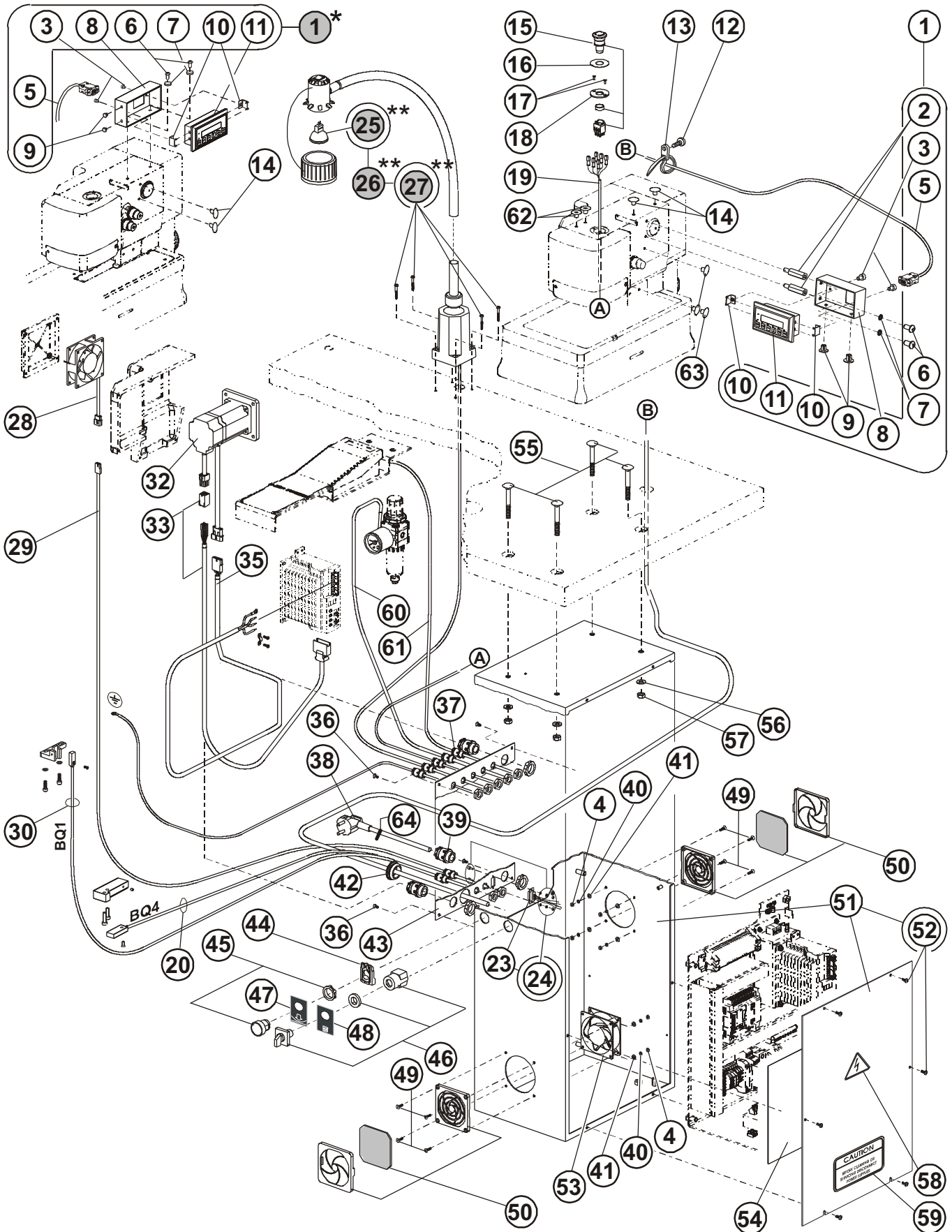

ELECTRICAL — II

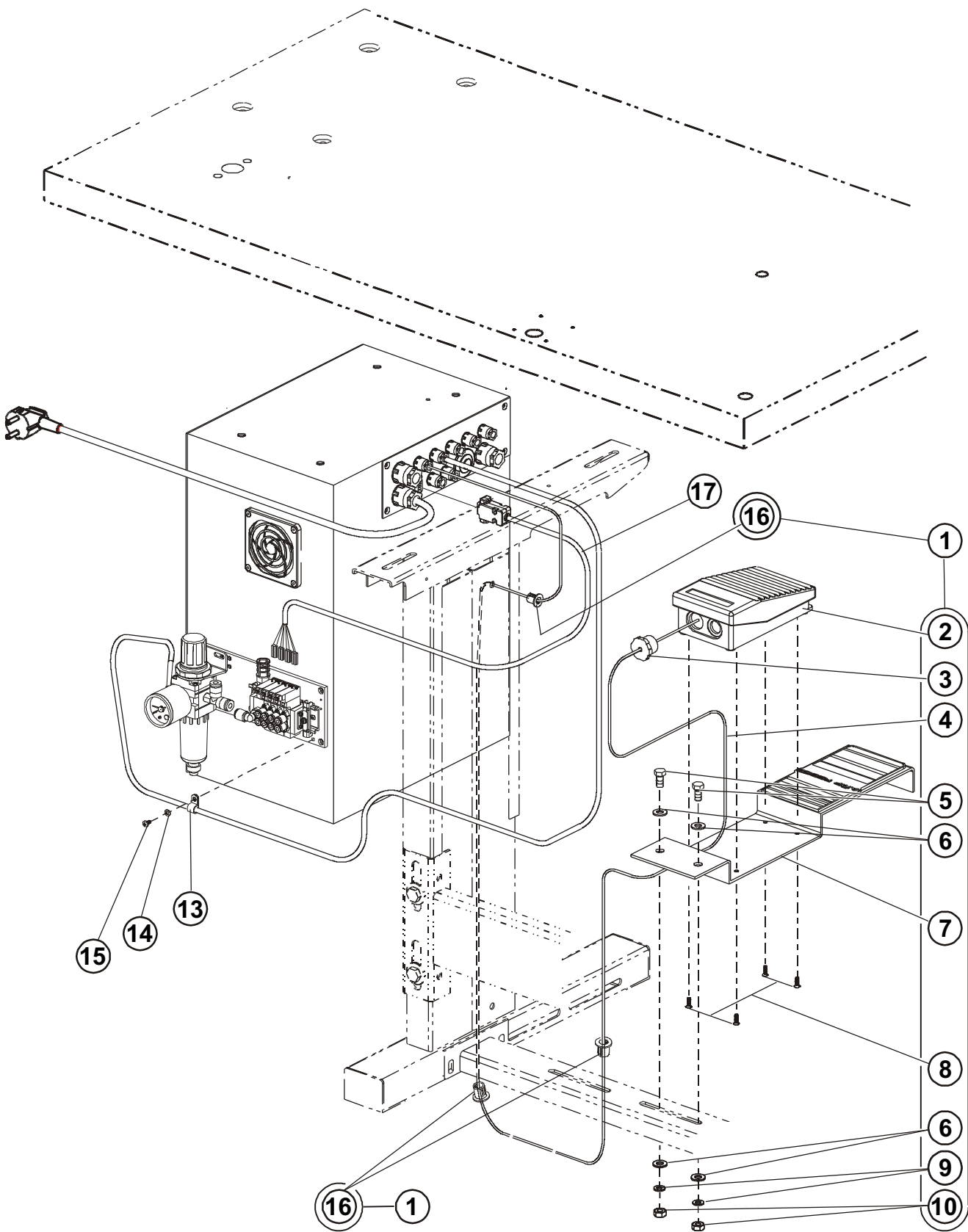

ELECTRICAL — III

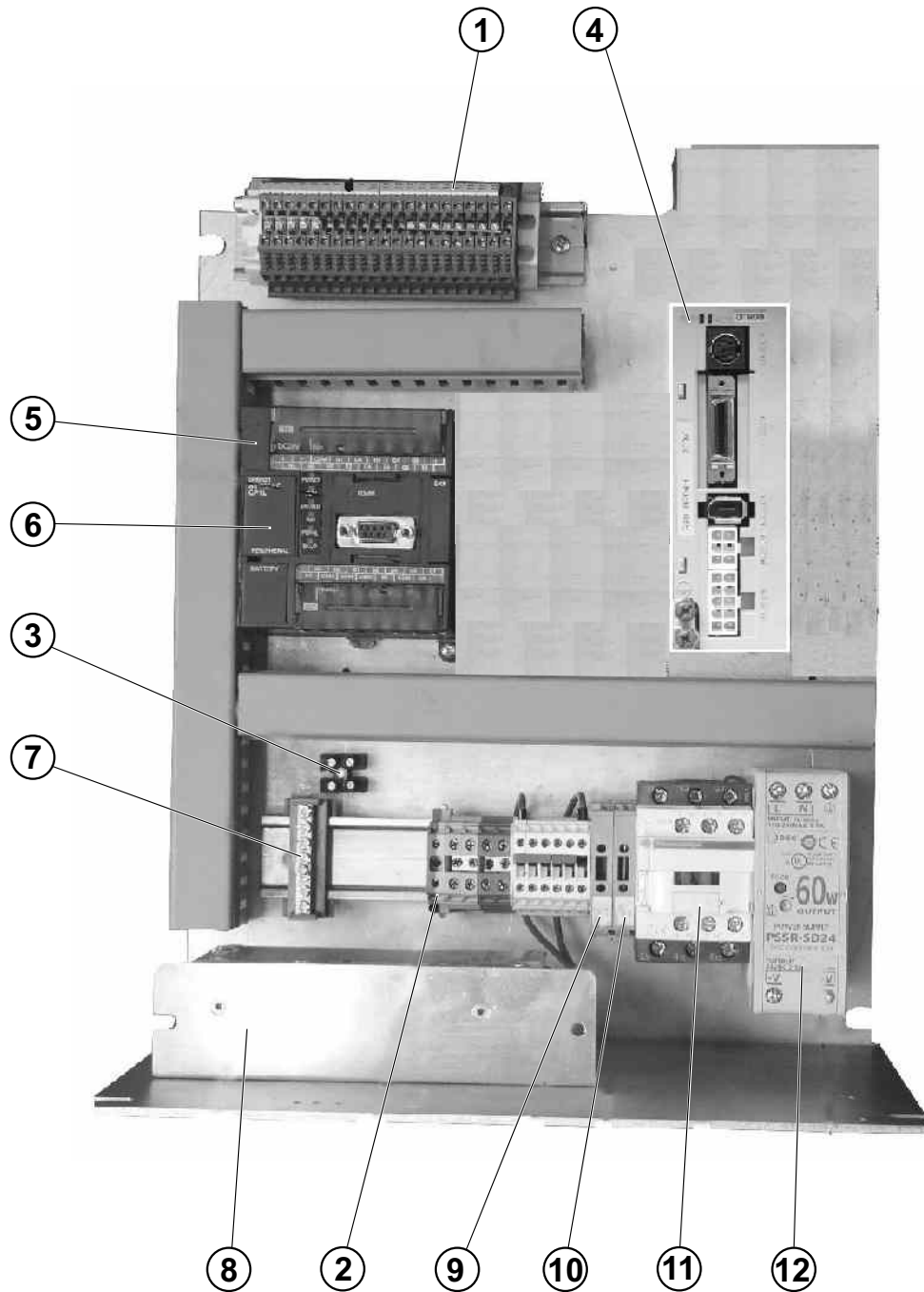

PNEUMATICS

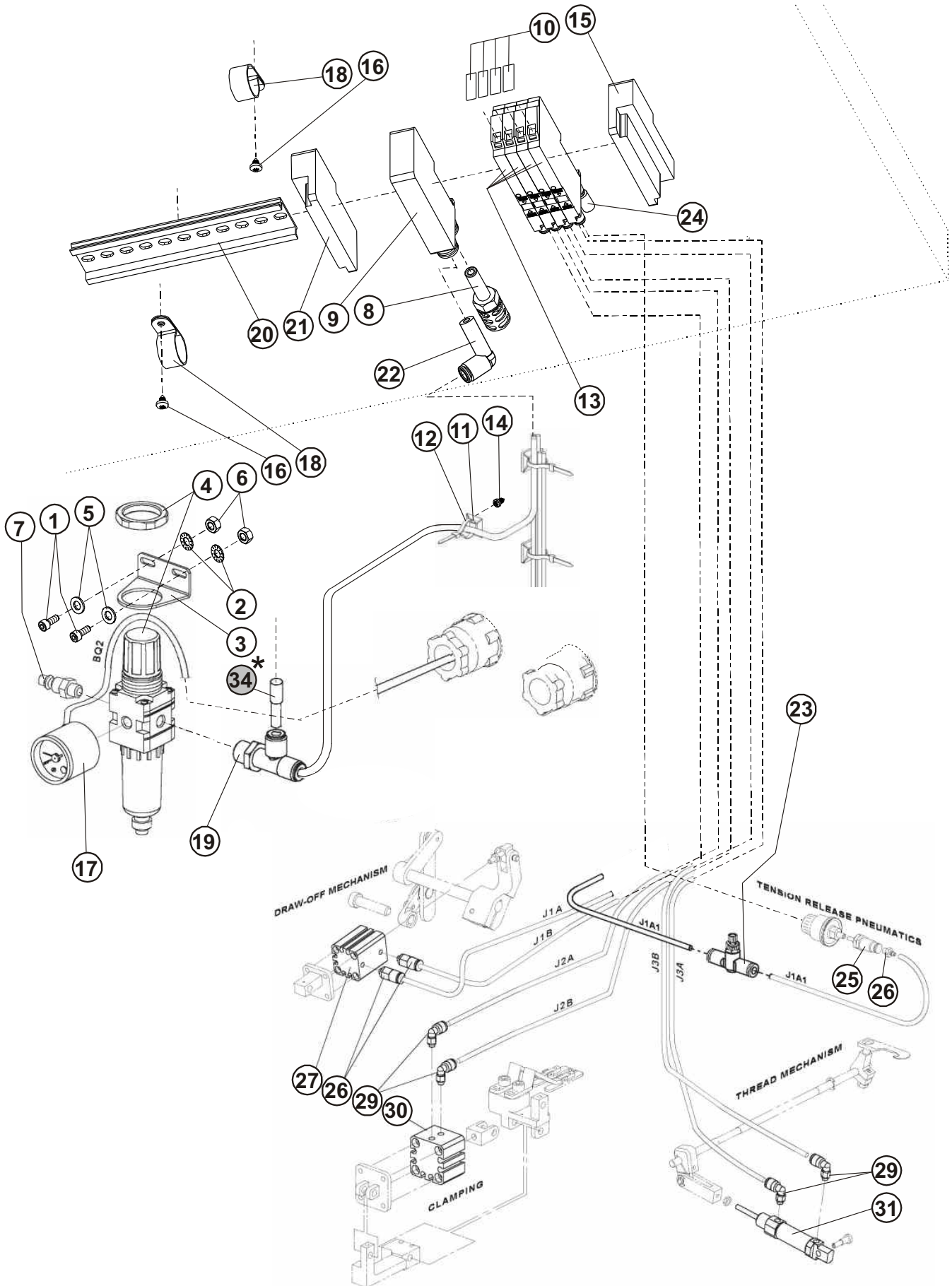

ACCESSORIES — EXTRA PARTS

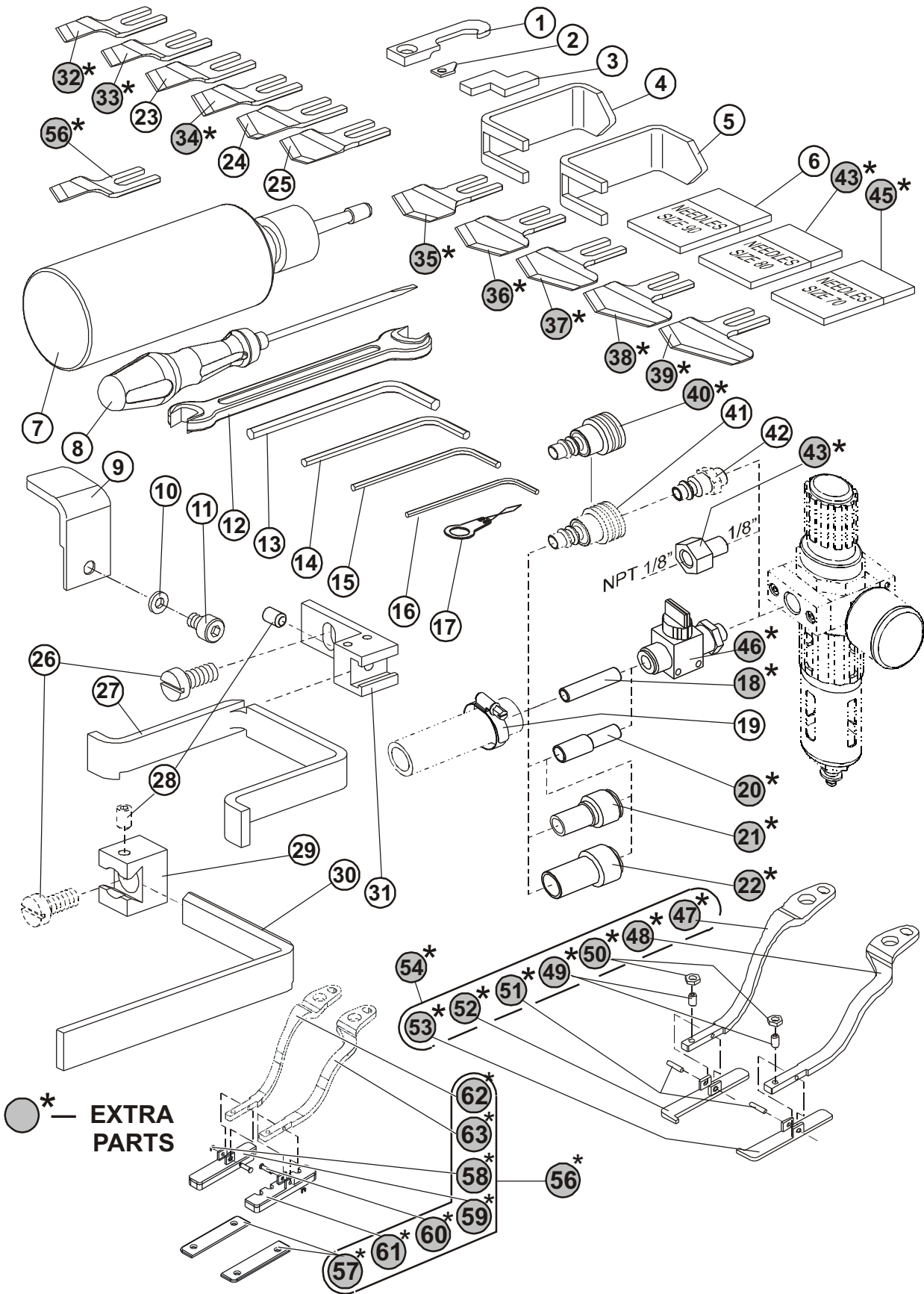

ACCESSORIES — EXTRA PARTS

DET	PART NUMBER	DESCRIPTION	QTY.
01	20.0093.2.004	Trimmer Hook	1
02	20.0094.0.000	Trimmer Knife	1
03	22.0209.0.000	Looper Gauge	1
04	24.0030.0.000	Main Shaft Pulley Bracket	1
05	24.0024.0.000	Needle Bar Shaft Pulley Bracket	1
06	02.0750.2.110	Needles, Size 90	10
07	05.1322.0.000	Oiler	●●● 1
08	12.0008.6.001	Screwdriver	1
09	22.0213.0.000	Bracket	1
10	08.6850.4.000	Washer M4	1
11	08.6000.4.005	Screw M4x5	1
12	12.0008.6.109	Wrench	1
13	12.0008.6.102	Allen Key Wrench 4	1
14	12.0008.6.101	Allen Key Wrench 3	1
15	12.0008.6.112	Allen Key Wrench 2-1/2	1
16	12.0008.6.100	Allen Key Wrench 2	1
17	12.0008.6.105	Needle Threader	1
18*	12.0008.3.464	Connector	●●● 1
19	12.0008.3.251	Air Tubing Clamp	1
20*	12.0008.3.466	Connector	●●● 1
21*	12.0008.3.467	Connector	●●● 1
22*	12.0008.3.465	Connector	●●● 1
23	23.2356.2.052	Knife 13mm	1
24	23.2356.2.054	Knife 16mm	1
25	23.2356.2.055	Knife 19mm	1
26	08.6010.5.008	Screw M5 x 8	1
27	22.0010.0.000	Crosswise Gauge	1
28	08.6400.4.005	Gauge Lock Screw M4 x 5	1
29	22.0011.0.000	Parallel Gauge Block	1
30	22.0012.0.000	Parallel Gauge	1
31	22.0044.0.000	Crosswise Gauge Guide	1
32*	23.2356.2.050	Knife 10mm	—
33*	23.2356.2.051	Knife 11mm	—
34*	23.2356.2.053	Knife 14mm	—
35*	23.2356.2.056	Knife 22mm	—
36*	23.2356.2.057	Knife 25mm	—
37*	23.2356.2.058	Knife 29mm	—
38*	23.2356.2.059	Knife 32mm	—
39*	23.2356.2.060	Knife 35mm	—
40*	12.0008.3.607	Connector Dia 8	
41	12.0008.3.608	Connector Dia 10	
42	12.0008.3.420	Connector	
43*	12.0008.3.081	Pneumatic Adapter (1/8" / NPT 1/8")	
44*	02.0750.2.100	Needle, Size 80	
45*	02.0750.2.109	Needle, Size 70	
46*	12.0008.3.463	Handvalve	
47*	24.0073.0.000	Clamp Arm, L.H.	
48*	24.0074.0.000	Clamp Arm, R.H.	
49*	08.6400.3.006	Set Screw, M3x6	
*	— EXTRA PARTS		

ACCESSORIES — EXTRA PARTS

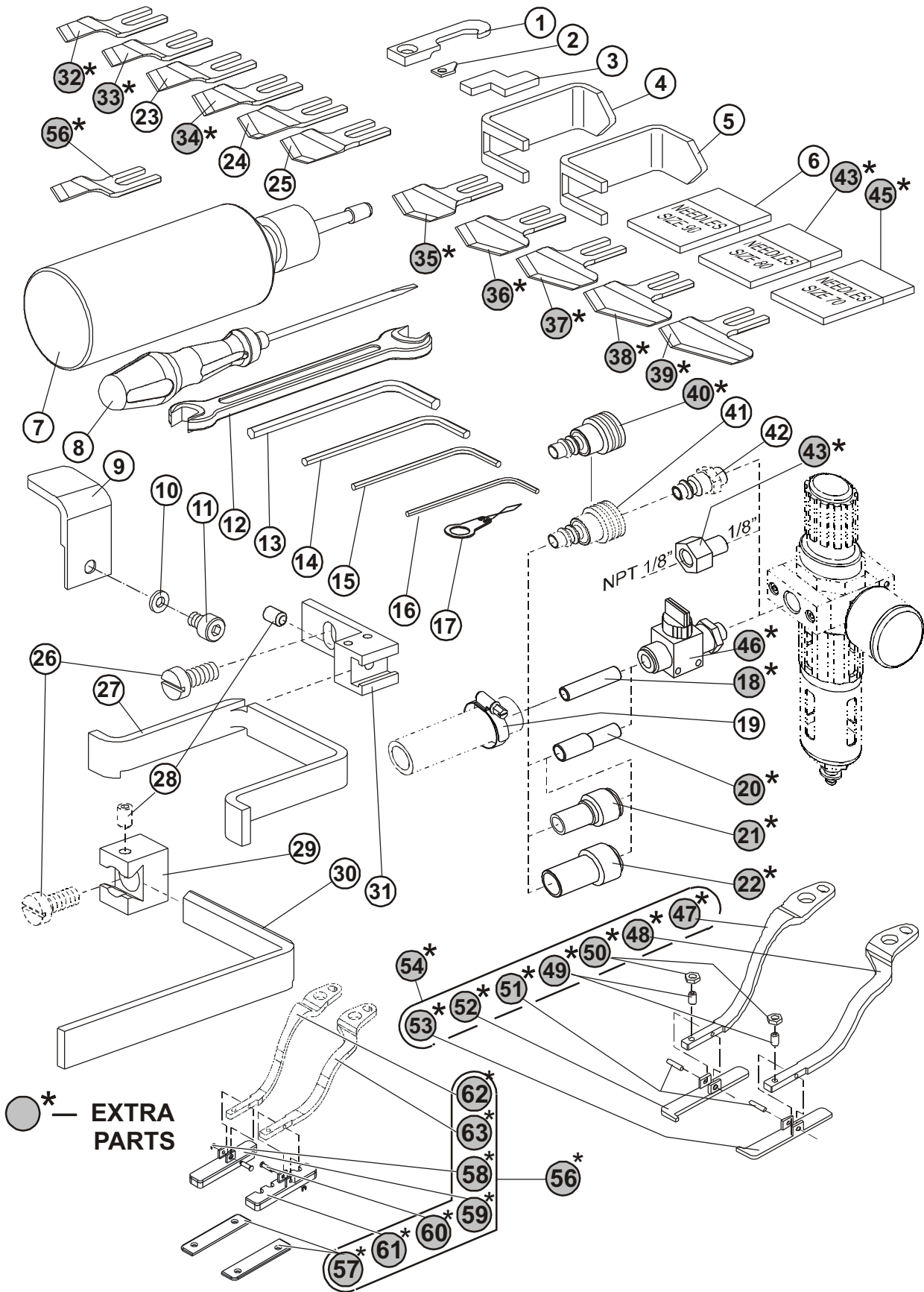

INDEX

PART NUMBER	PAGE	DET	QTY	PART NUMBER	PAGE	DET	QTY	PART NUMBER	PAGE	DET	QTY
00.2751.3.602	3-39	59	1	07.6440.0.037	3-23	04	2	08.6000.6.025	3-3	31	1
01.1382.0.000	3-15	06	1	07.6440.0.040	3-9	16	1	08.6000.6.025	3-19	01	1
01.1397.0.000	3-15	11	4	07.6440.0.041	3-11	11	1	08.6000.6.025	3-25	29	2
01.2084.0.000	3-5	10	1	07.6440.0.045	3-23	27	1	08.6000.6.030	3-3	15	(1)
01.2193.0.000	3-3	2	1	07.6440.0.050	3-11	18	1	08.6000.8.025	3-25	07	2
01.2376.0.000	3-5	17	4	07.6440.0.051	3-25	10	1	08.6000.8.030	3-37	02	(4)
01.2386.0.000	3-7	03	1	08.6000.3.006	3-21	29	1	08.6000.8.040	3-25	12	2
01.6551.0.000	3-3	7	1	08.6000.3.006	3-27	15	1	08.6010.5.008	3-49	26	1
01.6551.0.000	3-21	17	1	08.6000.3.006	3-31	11	1	08.6012.4.010	3-17	11	1
01.7447.1.000	3-3	5	1	08.6000.3.010	3-11	38	1	08.6032.4.010	3-39	52	(6)
01.7447.1.000	3-21	15	1	08.6000.3.010	3-15	17	1	08.6100.3.008	3-19	05	2
01.7804.0.000	3-3	18	1	08.6000.3.010	3-19	06	1	08.6100.3.008	3-27	21	2
01.7805.0.000	3-3	23	1	08.6000.3.016	3-29	09	4	08.6100.3.016	3-25	37	1
01.7805.0.000	3-27	37	2	08.6000.3.040	3-29	08	1	08.6100.3.030	3-11	01	2
01.7806.0.000	3-25	18	2	08.6000.4.005	3-9	05	4	08.6100.4.006	3-9	21	1
01.7809.0.000	3-3	17	1	08.6000.4.005	3-13	58	2	08.6100.4.006	3-27	8	2
02.0750.2.100	3-49	44*	0	08.6000.4.005	3-25	20	1	08.6100.4.010	3-39	36	4
02.0750.2.109	3-49	45*	0	08.6000.4.005	3-49	11	1	08.6100.4.012	3-23	15	1
02.0750.2.110	3-3	32	1	08.6000.4.006	3-21	39	1	08.6100.4.012	3-43	8	(4)
02.0750.2.110	3-49	06	10	08.6000.4.006	3-27	20	1	08.6100.4.014	3-39	49	1
03.5524.0.009	3-39	01	1	08.6000.4.006	3-29	15	2	08.6100.5.010	3-23	09	1
03.5524.0.009	3-39	01*	1	08.6000.4.006	3-31	04	2	08.6100.5.012	3-5	14	2
04.1416.0.003	3-33	09	(1)	08.6000.4.006	3-39	3	(2)	08.6100.5.012	3-17	02	5
04.1416.0.003	3-35	09	(1)	08.6000.4.010	3-9	01	2	08.6100.5.016	3-29	01	7
04.1416.0.003	3-37	09	(1)	08.6000.4.010	3-21	07	1	08.6100.5.020	3-15	04	2
04.9000.2.123	3-33	15	1	08.6000.4.012	3-7	07	1	08.6100.5.020	3-17	07	1
04.9000.2.123	3-35	15	1	08.6000.4.012	3-21	38	1	08.6100.5.020	3-25	26	3
04.9000.2.123	3-37	15	1	08.6000.4.014	3-11	45	2	08.6100.6.035	3-27	17	1
05.1322.0.000	3-49	07	1	08.6000.4.014	3-15	25	2	08.6100.8.012	3-37	26	(6)
06.8800.0.001	3-43	2	(1)	08.6000.4.014	3-19	08	2	08.6100.8.020	3-37	18	(4)
07.6045.0.009	3-11	19	2	08.6000.4.014	3-27	2	1	08.6102.3.008	3-39	17	2
07.6045.0.034	3-11	30	1	08.6000.4.016	3-9	03	4	08.6120.3.008	3-27	3	7
07.6045.0.037	3-11	16	2	08.6000.4.016	3-21	32	2	08.6200.4.008	3-29	17	2
07.6045.0.037	3-25	09	1	08.6000.4.016	3-27	44	1	08.6200.4.016	3-21	22	2
07.6045.0.042	3-7	09	1	08.6000.4.025	3-11	32	2	08.6200.5.008	3-25	05	1
07.6045.0.042	3-21	04	1	08.6000.4.070	3-29	07	4	08.6200.5.012	3-17	03	6
07.6045.0.046	3-5	01	2	08.6000.5.008	3-21	40	1	08.6200.5.020	3-17	16	1
07.6045.0.053	3-25	21	1	08.6000.5.012	3-5	07	1	08.6200.6.012	3-39	6	(2)
07.6045.0.054	3-27	11	1	08.6000.5.012	3-47	01	2	08.6200.6.016	3-39	12	1
07.6321.0.001	3-23	11	1	08.6000.5.016	3-3	37	1	08.6215.4.006	3-39	62	2
07.6321.0.025	3-11	50	2	08.6000.5.016	3-21	03	1	08.6300.0.070	3-37	35	(2)
07.6321.0.025	3-19	16	2	08.6000.5.016	3-25	03	8	08.6310.6.035	3-25	49	1
07.6321.0.029	3-19	13	(2)	08.6000.5.016	3-27	26	3	08.6312.8.020	3-43	5	(2)
07.6321.0.030	3-13	61	(1)	08.6000.5.020	3-11	15	2	08.6400.3.003	3-21	31	1
07.6440.0.018	3-11	41	2	08.6000.5.022	3-5	05	4	08.6400.3.004	3-27	23	2
07.6440.0.028	3-11	23	2	08.6000.5.040	3-21	10	4	08.6400.3.005	3-3	12	4
07.6440.0.028	3-19	18	2	08.6000.6.008	3-5	30	2	08.6400.3.006	3-5	27	2
07.6440.0.033	3-11	08	2	08.6000.6.016	3-3	22	2	08.6400.3.006	3-49	49*	0
07.6440.0.036	3-15	21	3	08.6000.6.016	3-27	31	2	08.6400.3.020	3-23	29	1

INDEX

PART NUMBER	PAGE	DET	QTY	PART NUMBER	PAGE	DET	QTY	PART NUMBER	PAGE	DET	QTY
08.6400.4.004	3-3	21	2 (2)	08.6702.8.000	3-43	10	(2)	12.0008.3.413	3-47	25	1
08.6400.4.004	3-5	08	2	08.6710.0.300	3-37	33	(4)	12.0008.3.418	3-47	17	1
08.6400.4.004	3-15	01	2	08.6710.3.000	3-5	26	2	12.0008.3.420	3-47	07	1
08.6400.4.004	3-19	27	1	08.6710.3.000	3-51	50*	0	12.0008.3.420	3-49	42	0
08.6400.4.004	3-21	26	1	08.6710.5.000	3-13	52	2	12.0008.3.426	3-47	24	1
08.6400.4.005	3-9	22	1	08.6710.5.000	3-15	23	2	12.0008.3.433	3-47	27	1
08.6400.4.005	3-11	28	6	08.6710.6.000	3-21	01	1	12.0008.3.437	3-47	34*	1
08.6400.4.005	3-19	20	1	08.6733.3.000	3-11	24	2	12.0008.3.463	3-49	46*	0
08.6400.4.005	3-49	28	1	08.6742.8.000	3-33	11	(4)	12.0008.3.464	3-49	18*	1
08.6400.4.012	3-5	21	1	08.6742.8.000	3-35	11	(4)	12.0008.3.465	3-49	22*	1
08.6400.5.005	3-3	4	1	08.6742.8.000	3-37	11	(4)	12.0008.3.466	3-49	20*	1
08.6400.5.005	3-5	18	1	08.6752.8.000	3-33	22	(4)	12.0008.3.467	3-49	21*	1
08.6400.5.005	3-11	33	1	08.6752.8.000	3-35	22	(4)	12.0008.3.607	3-49	40*	0
08.6400.5.005	3-25	27	2	08.6752.8.000	3-37	22	(4)	12.0008.3.608	3-49	41	0
08.6400.5.005	3-27	12	2	08.6800.4.000	3-11	43	2	12.0008.3.828	3-47	13	4
08.6400.5.008	3-25	28	2	08.6800.4.000	3-15	26	2	12.0008.3.829	3-47	09	1
08.6400.5.010	3-25	17	1	08.6800.4.000	3-21	19	2	12.0008.3.830	3-47	15	1
08.6400.5.010	3-27	13	2	08.6802.4.000	3-39	40	4	12.0008.3.831	3-47	21	1
08.6400.5.305	3-11	13	4	08.6802.8.000	3-43	9	(2)	12.0008.3.832	3-47	20	1
08.6400.5.305	3-27	33	6	08.6832.4.000	3-17	12	1	12.0008.3.879	3-43	17	1
08.6532.8.055	3-33	19	(4)	08.6832.5.000	3-47	02	1	12.0008.4.050	3-45	7	1
08.6532.8.055	3-35	19	(4)	08.6832.6.000	3-39	7	(2)	12.0008.4.052	3-17	10	1
08.6532.8.055	3-37	19	(4)	08.6850.0.000	3-37	34	(4)	12.0008.4.058	3-47	11	4
08.6662.3.006	3-47	14	2	08.6850.3.000	3-21	27	1	12.0008.4.100	3-17	17	1
08.6663.5.025	3-33	13	10	08.6850.4.000	3-7	13	1	12.0008.4.155	3-39	58	1
08.6663.5.025	3-35	13	10	08.6850.4.000	3-21	18	2	12.0008.4.197	3-17	08	1
08.6663.5.025	3-37	13	10	08.6850.4.000	3-27	19	1	12.0008.4.207	3-39	37	7
08.6683.4.007	3-43	15	1	08.6850.4.000	3-49	10	1	12.0008.4.214	3-43	16	(3)
08.6683.4.007	3-47	16	2	08.6850.5.000	3-23	20	1	12.0008.4.231	3-39	39	3
08.6700.3.000	3-23	30	1	08.6850.5.000	3-25	02	7	12.0008.4.280	3-43	13	1
08.6700.3.000	3-25	38	1	08.6850.5.000	3-27	25	2	12.0008.4.280	3-47	18	2
08.6700.4.000	3-5	22	1	08.6850.5.000	3-29	04	4	12.0008.4.296	3-43	3	(1)
08.6700.4.000	3-7	11	1	08.6850.5.000	3-47	05	2	12.0008.4.366	3-39	42	1
08.6700.4.000	3-21	33	1	08.6850.6.000	3-25	30	2	12.0008.4.403	3-39	26**	1
08.6700.5.000	3-17	09	2	08.6850.8.000	3-13	56	1	12.0008.4.563	3-39	15	1
08.6700.5.000	3-19	24	2	08.6850.8.000	3-15	32	1	12.0008.4.565	3-39	2	(2)
08.6700.5.000	3-23	19	1	08.6852.4.000	3-39	41	4	12.0008.4.570	3-39	14	2
08.6700.5.000	3-25	34	3	08.6852.4.000	3-43	14	1	12.0008.4.571	3-39	9	(2)
08.6700.5.000	3-47	06	2	08.6852.8.000	3-33	20	(4)	12.0008.4.574	3-39	5	(1)
08.6700.6.000	3-25	50	1	08.6852.8.000	3-35	20	(4)	12.0008.4.598	3-25	35	1
08.6700.6.000	3-37	31	(1)	08.6852.8.000	3-37	20	(4)	12.0008.4.664	3-45	10	1
08.6700.8.000	3-13	57	1	08.6852.8.000	3-43	6	(4)	12.0008.4.665	3-45	9	1
08.6700.8.000	3-15	33	1	08.6887.5.000	3-9	17	1	12.0008.4.679	3-39	25**	(1)
08.6700.8.000	3-33	02	(4)	12.0008.3.023	3-25	13	1	12.0008.4.710	3-39	24	1
08.6700.8.000	3-35	02	(4)	12.0008.3.023	3-31	14	1	12.0008.4.713	3-39	38	1
08.6702.4.000	3-39	4	8	12.0008.3.023	3-47	12	4	12.0008.4.762	3-39	50	2
08.6702.8.000	3-33	21	(4)	12.0008.3.081	3-49	43*	0	12.0008.4.833	3-45	11	1
08.6702.8.000	3-35	21	(4)	12.0008.3.251	3-49	19	1	12.0008.4.835	3-39	46	1
08.6702.8.000	3-37	21	(4)	12.0008.3.412	3-47	30	1	12.0008.4.861	3-39	45	1

INDEX

PART NUMBER	PAGE	DET	QTY	PART NUMBER	PAGE	DET	QTY	PART NUMBER	PAGE	DET	QTY
12.0008.4.863	3-39	44	1	12.8000.0.040	3-39	48	1	22.0031.0.000	3-13	51	2
12.0008.6.001	3-49	08	1	12.8000.0.041	3-39	47	1	22.0031.0.000	3-15	15	2
12.0008.6.100	3-49	16	1	12.8000.0.045	3-39	54	1	22.0032.0.000	3-11	49	2
12.0008.6.101	3-49	14	1	12.8000.0.047	3-39	16	1	22.0033.0.000	3-19	25	1
12.0008.6.102	3-49	13	1	17.0019.0.441	3-33	03	(4)	22.0044.0.000	3-49	31	1
12.0008.6.105	3-49	17	1	17.0019.0.441	3-35	03	(4)	22.0046.0.000	3-21	16	1
12.0008.6.109	3-49	12	1	17.0019.0.441	3-37	03	(4)	22.0049.0.000	3-11	31	1
12.0008.6.112	3-49	15	1	17.0019.0.517	3-11	37	1	22.0054.0.000	3-25	06	1
12.0008.6.800	3-19	23	1	17.0019.2.057	3-11	25	1	22.0057.0.000	3-29	14	1
12.0008.6.801	3-33	06	(4)	17.0027.1.799	3-31	09	1	22.0058.0.000	3-25	08	1
12.0008.6.801	3-35	06	(4)	17.0031.0.460	3-5	25	2	22.0061.0.000	3-11	07	1
12.0008.6.807	3-37	25	(2)	17.0031.0.460	3-51	51*	0	22.0062.0.000	3-25	11	1
12.0008.6.900	3-33	05	(1)	17.0082.6.000	3-31	10	1	22.0063.0.000	3-19	04	1
12.0008.6.900	3-35	05	(1)	17.0082.8.082	3-25	23	2	22.0064.0.000	3-15	16	1
12.0008.6.900	3-37	05	(1)	17.0094.0.200	3-33	14	(4)	22.0064.0.000	3-19	14	2
12.0008.6.901	3-33	16	(1)	17.0094.0.200	3-35	14	(4)	22.0069.0.000	3-19	21	1
12.0008.6.901	3-35	16	(1)	17.0094.0.200	3-37	14	(4)	22.0091.0.000	3-21	24	1
12.0008.6.901	3-37	16	(1)	17.0094.5.310	3-31	12	1	22.0096.0.000	3-27	7	1
12.0010.3.027	3-47	26	3	17.0095.1.272	3-33	04	(4)	22.0097.0.000	3-23	13	1
12.0010.3.028	3-47	29	4	17.0095.1.272	3-35	04	(4)	22.0100.0.000	3-11	34	4
12.0010.3.029	3-47	23	1	17.0095.1.272	3-37	04	(8)	22.0100.0.000	3-15	20	3
12.0010.3.030	3-47	08	1	17.0095.1.329	3-31	07	1	22.0100.0.000	3-19	11	4
12.0010.3.031	3-47	22	1	20.0051.1.024	3-5	15	1	22.0104.0.000	3-31	06	1
12.0010.3.032	3-47	19	1	20.0092.0.004	3-7	02	1	22.0105.0.000	3-15	29	1
12.0010.3.137	3-47	04	1	20.0093.2.004	3-7	01	1	22.0106.0.000	3-23	25	2
12.0010.3.138	3-47	03	1	20.0093.2.004	3-49	1	1	22.0107.0.000	3-31	13	1
12.0010.4.013	3-3	38	1	20.0094.0.000	3-15	07	1	22.0108.0.000	3-31	08	1
12.0010.4.013	3-39	13	1	20.0094.0.000	3-49	02	1	22.0110.0.000	3-13	54	1
12.0010.4.067	3-45	6	1	20.0111.0.000	3-15	08	1	22.0110.0.000	3-19	09	1
12.0010.4.071	3-45	12	1	20.0112.0.000	3-15	10	1	22.0114.0.000	3-11	02	1
12.0010.4.078	3-45	8	1	22.0006.0.000	3-27	34	1	22.0115.0.000	3-27	43	1
12.0010.4.094	3-39	63	3	22.0008.0.000	3-19	02	1	22.0120.0.000	3-31	05	1
12.1010.2.003	3-25	33	1	22.0009.0.000	3-19	12	(1)	22.0121.0.000	3-11	03	1
12.1011.0.001	3-25	36	1	22.0009.0.050	3-19	28	1	22.0137.0.000	3-23	10	2
12.1016.1.000	3-33	08	(6)	22.0010.0.000	3-49	27	1	22.0143.0.000	3-27	6	2
12.1016.1.000	3-35	08	(6)	22.0011.0.000	3-49	29	1	22.0145.0.000	3-21	34	1
12.1016.1.000	3-37	08	(6)	22.0012.0.000	3-49	30	1	22.0153.0.000	3-27	38	2
12.1040.1.009	3-37	29	(1)	22.0020.0.000	3-19	22	1	22.0159.0.000	3-5	20	1
12.1045.0.012	3-51	58*	2	22.0021.0.000	3-11	47	1	22.0164.0.000	3-5	16	1
12.1045.2.001	3-3	29	1	22.0021.0.000	3-15	27	1	22.0173.0.000	3-5	02	2
12.1045.2.001	3-27	36	1	22.0022.0.000	3-13	55	1	22.0175.0.000	3-3	27	1
12.1045.3.001	3-7	04	1	22.0022.0.000	3-15	31	1	22.0177.0.000	3-3	35	2
12.2010.1.002	3-15	14	2	22.0023.0.000	3-15	28	1	22.0178.0.000	3-3	34	1
12.2050.0.003	3-3	20	1	22.0024.0.000	3-15	22	1	22.0182.0.000	3-23	12	2
12.2050.0.005	3-27	30	1	22.0026.0.000	3-11	40	1	22.0183.0.000	3-11	39	1
12.4030.0.002	3-27	27	1	22.0027.0.000	3-19	19	1	22.0183.0.000	3-15	18	1
12.5050.2.009	3-25	15	1	22.0028.0.000	3-19	17	2	22.0183.0.000	3-19	07	1
12.8000.0.016	3-17	06	1	22.0029.0.000	3-19	15	2	22.0184.0.000	3-11	21	3
12.8000.0.016	3-47	10	1	22.0030.0.000	3-19	26	1	22.0186.0.000	3-11	27	1

INDEX

PART NUMBER	PAGE	DET	QTY	PART NUMBER	PAGE	DET	QTY	PART NUMBER	PAGE	DET	QTY
22.0195.0.000	3-3	1	1	22.1415.0.050	3-21	11	1	23.2356.2.056	3-49	35*	—
22.0208.0.000	3-11	26	1	22.1422.0.000	3-25	22	1	23.2356.2.057	3-49	36*	—
22.0209.0.000	3-49	03	1	22.1426.0.000	3-21	37	1	23.2356.2.058	3-49	37*	—
22.0213.0.000	3-49	09	1	22.1430.0.901	3-21	20	1	23.2356.2.059	3-49	38*	—
22.0214.0.000	3-19	10	1	22.1436.0.000	3-21	14	2	23.2356.2.060	3-49	39*	0
22.0219.0.000	3-33	17	1	22.1442.0.000	3-21	35	1	24.0001.0.000	3-3	33	1
22.0219.0.000	3-35	17	1	22.1443.0.000	3-21	36	1	24.0002.0.000	3-3	28	1
22.0219.0.000	3-37	17	1	22.2410.0.000	3-15	03	1	24.0002.0.000	3-27	32	1
22.0223.0.000	3-5	24	1	22.2425.0.050	3-15	19	1	24.0003.0.000	3-7	06	1
22.0223.4.000	3-51	59*	1	22.2440.0.000	3-15	05	2	24.0004.0.000	3-7	08	1
22.0224.0.000	3-5	23	1	22.2442.0.000	3-15	02	2	24.0005.0.000	3-7	10	1
22.0226.0.000	3-5	29	1	22.2600.0.000	3-23	08	1	24.0006.0.000	3-7	14	1
22.0226.0.000	3-51	62*	1	22.2607.0.000	3-23	01	1	24.0009.0.000	3-21	09	1
22.0227.0.000	3-5	28	1	22.2610.0.000	3-23	14	1	24.0010.0.000	3-21	08	1
22.0227.0.000	3-51	63*	1	22.2620.0.000	3-23	06	1	24.0011.0.000	3-21	05	1
22.0228.0.000	3-11	12	1	22.2626.0.000	3-23	03	1	24.0014.0.000	3-21	06	1
22.0229.0.000	3-31	03	2	22.2627.0.000	3-23	02	2	24.0016.0.000	3-25	32	1
22.0230.0.000	3-3	8	2	22.2631.0.000	3-23	24	1	24.0018.0.000	3-27	14	1
22.0232.0.000	3-13	53	1	22.2633.0.000	3-23	23	1	24.0019.0.000	3-27	29	1
22.0232.0.000	3-15	24	1	22.2635.0.000	3-23	16	1	24.0020.0.000	3-27	24	1
22.0233.0.000	3-15	30	1	22.2637.0.000	3-23	22	1	24.0021.0.000	3-27	1	1
22.0239.0.000	3-3	9	2	22.2638.0.000	3-23	17	1	24.0024.0.000	3-49	05	1
22.0300.0.000	3-27	40	1	22.2639.0.000	3-23	18	1	24.0027.0.000	3-27	42	2
22.0305.0.000	3-11	35	1	22.2640.0.050	3-23	26	1	24.0030.0.000	3-49	04	1
22.0309.0.000	3-11	20	(1)	22.2651.0.000	3-9	15	1	24.0035.0.000	3-5	06	1
22.0309.0.050	3-13	59	1	22.2652.0.000	3-9	04	1	24.0036.0.000	3-5	03	1
22.0312.0.000	3-11	06	1	22.2653.0.000	3-9	02	1	24.0037.0.000	3-21	02	1
22.0313.0.000	3-11	17	(1)	22.2655.0.000	3-9	18	1	24.0038.0.000	3-17	05	1
22.0315.0.000	3-11	22	1	22.2656.0.000	3-9	07	1	24.0039.0.000	3-21	13	1
22.0320.0.000	3-11	36	1	22.2657.0.000	3-9	06	1	24.0044.0.000	3-25	19	1
22.0325.0.000	3-11	10	1	22.2664.0.000	3-9	24	1	24.0048.0.000	3-3	26	1
22.0336.0.000	3-11	44	1	22.2665.0.000	3-9	19	1	24.0049.0.000	3-11	14	2
22.0353.0.000	3-11	48	3	22.3003.0.000	3-23	28	1	24.0050.0.000	3-47	31	1
22.0354.0.000	3-11	04	1	22.3069.0.000	3-23	07	1	24.0051.0.066	3-27	16	1
22.0370.0.000	3-11	46	1	22.3219.0.000	3-27	18	1	24.0055.0.000	3-19	03	1
22.0400.0.000	3-9	23	1	22.6002.0.000	3-25	25	1	24.0059.9.017	3-39	53	1
22.0405.0.000	3-9	14	1	22.6101.0.000	3-27	4	1	24.0059.9.064	3-39	32	1
22.0408.1.000	3-27	9	1	22.8400.0.000	3-27	39	1	24.0059.9.065	3-33	12	1
22.0520.0.000	3-3	6	1	23.2044.0.050	3-25	24	2	24.0059.9.065	3-35	12	1
22.0525.0.000	3-3	16	(1)	23.2106.0.000	3-15	09	1	24.0059.9.065	3-37	12	1
22.0525.0.050	3-3	24	1	23.2107.0.000	3-15	12	1	24.0059.9.069	3-39	28	1
22.0530.0.000	3-3	10	1	23.2356.1.049	3-51	55*	0	24.0061.0.000	3-21	28	1
22.0535.0.100	3-3	30	1	23.2356.2.050	3-49	32*	—	24.0062.0.000	3-21	21	1
22.0540.0.000	3-3	14	1	23.2356.2.051	3-49	33*	—	24.0063.0.000	3-21	25	1
22.0541.0.000	3-3	13	1	23.2356.2.052	3-21	41	1	24.0066.0.000	3-15	13	2
22.0542.0.000	3-3	11	1	23.2356.2.052	3-49	23	1	24.0067.0.000	3-29	03	1
22.0545.0.000	3-3	25	1	23.2356.2.053	3-49	34*	—	24.0068.0.000	3-29	02	1
22.0545.0.000	3-27	41	1	23.2356.2.054	3-49	24	1	24.0069.9.002	3-39	35	1
22.1010.0.000	3-17	04	2	23.2356.2.055	3-49	25	1	24.0069.9.003	3-43	4	(1)

INDEX

PART NUMBER	PAGE	DET	QTY	PART NUMBER	PAGE	DET	QTY	PART NUMBER	PAGE	DET	QTY
24.0069.9.006	3-39	30	1	24.0500.0.000	3-3	19	1				
24.0069.9.008	3-39	33	1	24.0510.0.000	3-3	3	1				
24.0069.9.009	3-43	1	1	24.0546.0.000	3-25	51	1				
24.0069.9.022	3-39	20	1	24.1000.0.000	3-27	28	1				
24.0069.9.023	3-39	19	1	24.2035.0.000	3-11	29	1				
24.0069.9.024	3-39	23	1	24.2055.0.000	3-51	60*	2				
24.0069.9.027	3-39	29	1	24.2400.0.000	3-27	35	1				
24.0071.0.000	3-51	52*	0	24.2630.1.000	3-23	21	1				
24.0072.0.000	3-51	53*	0	24.3209.0.000	3-5	19	1				
24.0073.0.000	3-49	47*	0	24.3210.0.000	3-5	09	1				
24.0074.0.000	3-49	48*	0	24.6000.5.000	3-25	04	1				
24.0079.0.000	3-37	23	(1)	24.6001.2.000	3-29	10	1				
24.0080.0.000	3-7	05	1	24.6003.0.000	3-29	13	1				
24.0081.0.000	3-37	06	(6)	24.6004.1.001	3-29	06	1				
24.0082.0.000	3-37	07	0	24.6005.1.002	3-17	13	1				
24.0084.0.000	3-37	28	(8)	24.6100.0.000	3-27	10	1				
24.0086.0.000	3-37	24	(1)	24.8001.0.005	3-39	11	(1)				
24.0087.0.000	3-37	30	(2)	24.8001.2.001	3-45	5	1				
24.0089.0.000	3-37	32	(1)	24.8001.2.005	3-45	4	0				
24.0093.0.000	3-21	23	1	24.9920.9.988	3-51	56*	0				
24.0094.0.000	3-21	30	1	24.9920.9.990	3-51	54*	0				
24.0097.0.000	3-43	7	(1)	70.4165.1.125	3-39	51	1				
24.0100.0.000	3-3	36	1								
24.0106.0.000	3-25	31	1								
24.0108.0.000	3-25	16	1								
24.0111.0.000	3-17	01	1								
24.0112.0.000	3-29	11	1								
24.0125.0.000	3-5	12	1								
24.0126.0.000	3-11	05	1								
24.0127.0.000	3-11	42	1								
24.0138.0.000	3-39	43	1								
24.0139.0.000	3-31	02	1								
24.0140.0.000	3-13	60	1								
24.0141.0.000	3-31	01	1								
24.0142.0.000	3-33	10	(1)								
24.0142.0.050	3-33	01	1								
24.0145.1.000	3-47	32	1								
24.0146.0.000	3-39	8	(1)								
24.0147.0.000	3-39	10	(2)								
24.0148.0.000	3-39	18	1								
24.0149.0.000	3-35	10	(1)								
24.0149.0.050	3-35	01	1								
24.0150.0.000	3-37	10	(1)								
24.0150.0.050	3-37	01	1								
24.0151.0.000	3-23	05	1								
24.0154.0.000	3-29	16	1								
24.0165.0.000	3-51	57*	2								
24.0224.4.000	3-51	61*	1								
24.0351.0.000	3-11	09	1								

INDEX
