



MorganTecnica

311 / 312 / 313

Semi Automatic Loaders Range

SEMI AUTOMATIC LOADERS

The **311**, **312**, and **313** loaders are the first element of the spreading line, and are semi-automatic systems for the loading of fabric rolls on spreaders with different capacities:

- 311 has a maximum capacity of 100 kg;
- 312 has a maximum capacity of 200 kg;
- 313 has a maximum capacity of 300 kg.

Through a special control panel, the operator checks the motorized roll loading system positioned on a cradle support. A special semi-automatic inclination device on the cradle helps the unloading of the roll loading, reducing the handling times.



Photo for illustration purposes only



311 / 312 / 313

LOADER 311 / TECHNICAL SPECIFICATIONS

| | |
|------------------------------|------------------|
| • Max. speed up/down | 5 m/min |
| • Max. roll weight | 100 Kg |
| • Max. roll diameter | 60 cm |
| • Installed electrical power | 0,5 Kw |
| • Average power consumption | 0,5 Kw |
| • Voltage / Frequency | 400 V + 50/60 Hz |

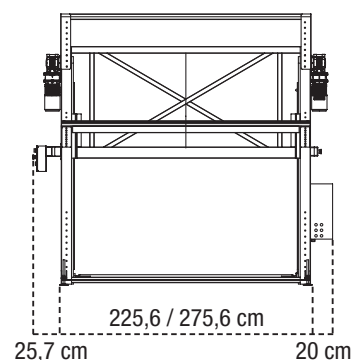
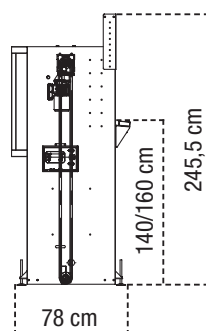

LOADER 312 / TECHNICAL SPECIFICATIONS

| | |
|------------------------------|------------------|
| • Max. speed up/down | 5 m/min |
| • Max. roll weight | 200 Kg |
| • Max. roll diameter | 80 cm |
| • Installed electrical power | 0,5 Kw |
| • Average power consumption | 0,5 Kw |
| • Voltage / Frequency | 400 V + 50/60 Hz |

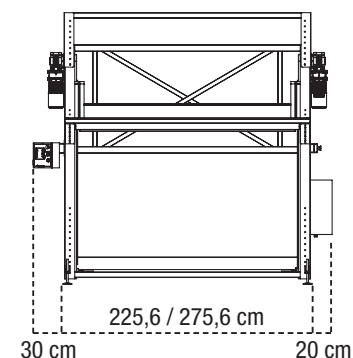
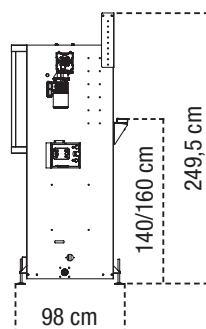

LOADER 313 / TECHNICAL SPECIFICATIONS

| | |
|------------------------------|------------------|
| • Max. speed up/down | 5 m/min |
| • Max. roll weight | 300 Kg |
| • Max. roll diameter | 1 m |
| • Installed electrical power | 1 Kw |
| • Average power consumption | 1 Kw |
| • Voltage / Frequency | 400 V + 50/60 Hz |

