



MorganTecnica

320

Automatic Loaders Range

AUTOMATIC LOADER

Loader **320** for the roll storage and handling. The structure includes a storage area with a conveyORIZED multi-level platforms. The lower one is dedicated to the pre-loading of rolls already in the correct sequence. The upper one is dedicated to collecting the used rolls,

unloaded by the spreader machine. The roll loading/off-loading system is managed in a fully automatic mode in order to minimize the idle time of the spreader machine and improve its productivity.

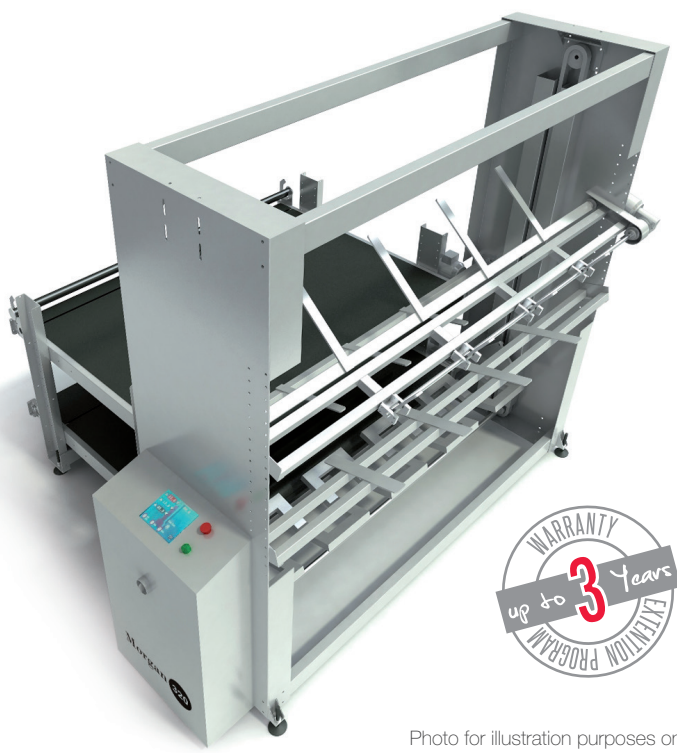
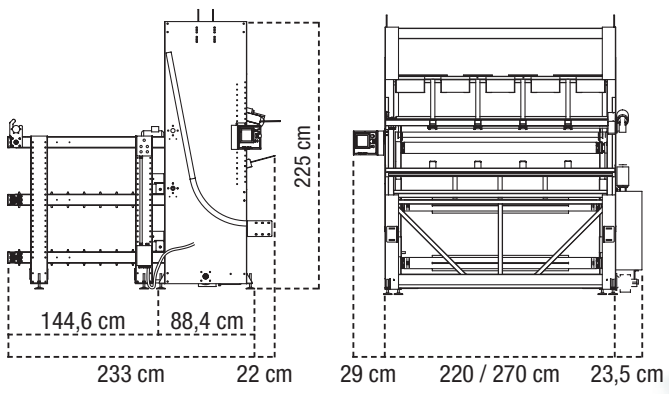

Photo for illustration purposes only

TECHNICAL SPECIFICATIONS

• Max. speed up/down	6 m/min
• Max. roll weight	50 Kg
• Max. roll diameter	30 cm
• Installed electrical power	2 Kw
• Average power consumption	2 Kw
• Voltage / Frequency	400 V + 50/60 Hz

www.morgantecnica.com
marketing@morgantecnica.com

ITALY / INDIA / CANADA / HONG KONG / USA / VIETNAM

