

MorganTecnica

103

Tables Range

MULTI-LEVEL TABLE

Table **103** is a 3 conveyor levels table for the storage of lays and automatic alignment of each level with the rest of the spreading tables. It is equipped with a motorized device that controls the vertical movement of the table and the automatic feed of each level selected with the worktable.

All tops are equipped with PVC conveyor belt with double side guide. The table can be synchronized with other tables or cuts automatic machines and is designed for lateral translation, in order to serve two or more parallel lines. Supplied in modules of 6 mt or 8 mt.

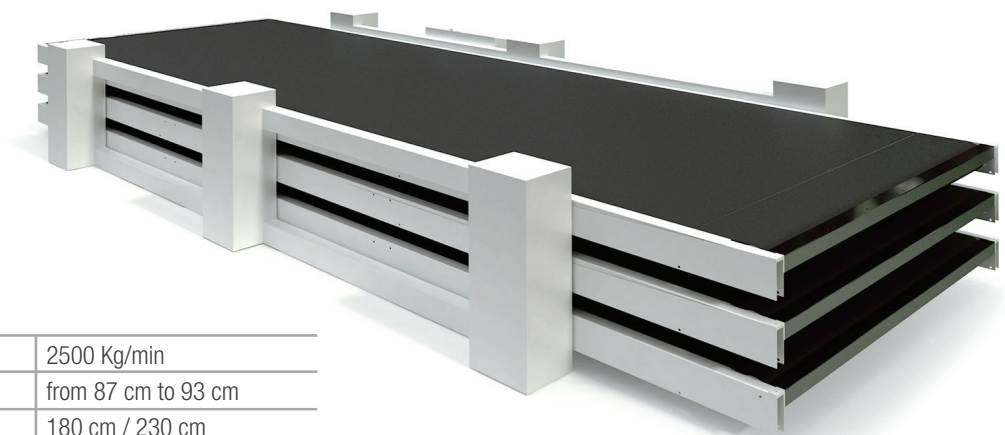

TECHNICAL SPECIFICATIONS

• Weight	2500 Kg/min
• Adjustable in height	from 87 cm to 93 cm
• Fabric width	180 cm / 230 cm
• Installed power	5,5 Kw
• Belt-speed	6 m/min

Photo for illustration purposes only

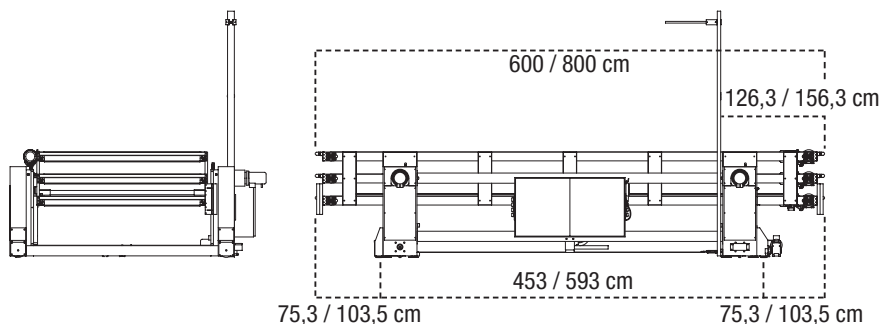

www.morgantecnica.com
marketing@morgantecnica.com

ITALY / INDIA / CANADA / HONG KONG / USA / VIETNAM

